



Part number: 1 987 721 540



Part number: 1 987 721 074



Part number: 1 987 721 021

**The proper drive for your products**

**D.C. motors with and without transmissions, blowers and pumps**

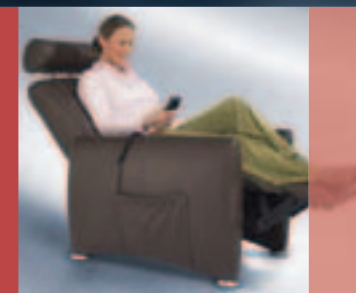

**The proper drive for your projects**

**Bosch electric motors for industrial applications**

Bosch provides a wide range of technically and economically interesting product solutions. Take advantage of our engineers' experience gathered from application in millions of automobiles and from many other industrial uses.

The ideal contact person can be found on the last page of the catalogue.



# Electric motors

2013 | 2014



# BOSCH

☎ 1 987 721 540/201210

AA/MK12 - 10.2012 - En  
© 2012 Robert Bosch GmbH  
Automotive Aftermarket  
P.O. Box 41 09 60  
76225 Karlsruhe, Germany  
Token fee: € 5,00

www.bosch-elektromotoren.de  
Copy deadline: 31.08.2012  
Subject to changes without notice!  
Please address your queries and information to our agency.  
With the publication of this issue all previous issues are rendered invalid.



# BOSCH



# The right drive for your projects – Bosch electric motors



## Electric motors from Bosch encourage movement in product development

With its competence, Bosch, as the leading global developer and manufacturer of automotive technology, has proved itself millions of times over in mobile applications. As a development partner to various industrial branches, Bosch is aligned to the requirements of its customers. Thus, Bosch electric motors are also the ideal solution for many applications outside of the automobile. The total of its advantages are immediately obvious, where quality, reliability and inexpensive prices through high-volume production are called for.

Industrial customers in particular, expect to have competent contact partners at their suppliers. To this end, an independent engineering team has been set up. Bosch engineers will advise and support you in the application engineering for D.C. motors, blowers and pumps. The proper contact person can be found on the last page of the catalogue.

[www.bosch-elektromotoren.de](http://www.bosch-elektromotoren.de)



# Bosch contacts worldwide for sales and advice

## Austria

Robert Bosch AG  
RBOS/SCC  
Mr. Andreas Chadt  
Geiereckstrasse 6  
AT - 1100 Wien  
Tel.: +43 (0)1 797 2261 16  
Fax: +43 (0)1 797 2225 6116  
Email: [Andreas.Chadt@at.bosch.com](mailto:Andreas.Chadt@at.bosch.com)

## Finland

Robert Bosch Oy  
AA/SIS1 FI  
Mr. Pekka Manninen  
Aeyritie 8 E  
01510 Vantaa  
Tel.: +385 (10) 480 827 8  
Fax: +358 (10) 480 835 7  
Email: [Pekka.Manninen@fi.bosch.com](mailto:Pekka.Manninen@fi.bosch.com)

## Korea

Robert Bosch Korea  
RBKR/SOK  
Mr. Hungdschun Ko  
298 Bojeong-dong Giheung-gu  
KR - 446-913 Yongin-si, Gyeonggi-do  
Tel.: +82 (0)31 260 3530  
Fax: +82 (0)31 260 3529  
Email: [Hungdschun.Ko@kr.bosch.com](mailto:Hungdschun.Ko@kr.bosch.com)

## Türkey

Bosch San. Ve Tic. A.Ş.  
AA/SOE-TR  
Mr. Fatih Meric  
Maslak Mh.  
Ahi Evran Cd. Polaris Plaza No: 21 Kat 22  
TR – 34398 Istanbul  
Tel.: +90 (0)212-335 0713  
Fax: +90 (0)212-346 0043  
Email: [Fatih.Metric@tr.bosch.com](mailto:Fatih.Metric@tr.bosch.com)

## Belgium

Robert Bosch SA/NV  
RBBN/SOE3  
Mr. Marc Jonckheere  
Rue Henri Genessestraat 1  
BE - 1070 Bruxelles  
Tel.: +32 (0)2 525 5271  
Fax: +32 (0)2 528 9430  
Email: [Marc.Jonckheere@be.bosch.com](mailto:Marc.Jonckheere@be.bosch.com)

## France

Bosch France SAS  
AA/SIS-Fr  
Mr. Olivier Theron  
126, Rue de Stalingrad  
FR-93705 Drancy Cedex  
Tel.: +33 (0)14-315 285  
Fax: +33 (0)14-315 469  
Email: [Olivier.Theron@fr.bosch.com](mailto:Olivier.Theron@fr.bosch.com)

## Norway

Robert Bosch AS  
AA/SEN3-SKI  
Mr. Erling Voll  
Berghagan 1  
NO - 1405 Langhus  
Tel.: +47 (0)64 878 938  
Fax: +47 (0)64 878 931  
Email: [Erling.Voll@no.bosch.com](mailto:Erling.Voll@no.bosch.com)

## Hungary

Robert Bosch Kft  
AA/SEA2  
Mr. Tudor Armasu  
Gyoemroei ut 120.  
HU - 1103 Budapest  
Tel.: +36 (0)1 431 3903  
Fax: +36 (0)1 431 3878  
Email: [Tudor.Armasu@ro.bosch.com](mailto:Tudor.Armasu@ro.bosch.com)

## Brazil

Robert Bosch Ltda  
AA/SIS-LA  
Mr. Souza Inivaldo  
Rod Anhanguera Km 98  
BR - 13065-900 Campinas, Sao Paulo  
Tel.: +55 (0)19 210 329 58  
Fax: +55 (0)19 210 330 62  
Email: [Inivaldo.Souza2@br.bosch.com](mailto:Inivaldo.Souza2@br.bosch.com)

## Germany

Robert Bosch GmbH  
AA/SIS1  
Mr. Michael Bode  
Auf der Breit 4  
DE - 76227 Karlsruhe  
Tel.: +49 (0)721 942 2278  
Fax: +49 (0)721 942 2643  
Email: [Michael.Bode@de.bosch.com](mailto:Michael.Bode@de.bosch.com)

## Poland

Robert Bosch Sp. z.o.o.  
AA/SPL1  
Mr. Andrzej Michocki  
Jutrzenki 105  
PL-02231 Warszawa  
Tel.: +48 (0)22-715 4518  
Fax: +48 (0)22-715 4597  
Email: [Andrzej.Michocki@pl.bosch.com](mailto:Andrzej.Michocki@pl.bosch.com)

## Romania

Robert Bosch SRL  
AA/SEA  
Mr. Tudor Armasu  
Horia Macelariu Str. 30-34  
RO-013937 Bucharest  
Tel.: +40 (21) 4057 621  
Fax: +40 (21) 2331 313  
Email: [Tudor.Armasu@ro.bosch.com](mailto:Tudor.Armasu@ro.bosch.com)

## Czech Republic

Robert Bosch Odbytova s.r.o.  
AA/SEM-SIS1  
Mr. David Komrska  
Pod visnovkou 35  
CZ - 140 00 Prague  
Tel.: +420 (0)2 613 005 04  
Fax: +420 (0)2 613 005 24  
Email: [David.Komrska@cz.bosch.com](mailto:David.Komrska@cz.bosch.com)

## Israel

Ledico Technologies LTD.  
Mr. Adi Tasman  
31 Lazarov Str.  
P.O.B. 17091  
IL - 75654 Rishon Le Zion  
Tel.: + 972 (0)3 963 0017  
Fax: + 972 (0)3 963 0066  
Email: [Tasman@lediko.com](mailto:Tasman@lediko.com)

## Sweden

Robert Bosch AB  
RBSN/SSC  
Mr. Erik Dahlen  
Vestagen 2A  
SE-41664 Göteborg  
Tel.: +46 (31) 722-5240  
Fax: +46 (31) 722-5299  
Email: [Erik.Dahlen@se.bosch.com](mailto:Erik.Dahlen@se.bosch.com)

## Great Britain

Robert Bosch Ltd  
AA/SIS1-GB  
Mr. Neil Hawes  
P.O.Box 98; Broadwater Park; North  
Orbital Road  
UK - UB9 5HJ Denham  
Tel.: +44 (0)1895 838 760  
Fax: +44 (0)1895 839 760  
Email: [Neil.Hawes@uk.bosch.com](mailto:Neil.Hawes@uk.bosch.com)

## China

Bosch Trading (Shanghai) Co., Ltd  
AA/SOE-CN  
Mr. Tiejun Guan  
333 Fuquan (N.) Road  
CN-200335 Shanghai  
Tel.: +86 (21) 2218-8647  
Fax: +86 (21) 6888-2211  
Email: [Tiejun.Guan@cn.bosch.com](mailto:Tiejun.Guan@cn.bosch.com)

## Italy

Robert Bosch SPA  
RBIT/SAA AA/SFI  
Mr. Trimarco Simona  
Via M.A. Colonna, 35  
IT - 20149 Milano  
Tel.: +39 (0)11 32 85 288  
Fax: +39 (0)11 32 85 250  
Email: [Simona.Trimarco@it.bosch.com](mailto:Simona.Trimarco@it.bosch.com)

## Switzerland

Robert Bosch AG  
RBCH/SOE1  
Mr. Gerold Brunner  
Industriestrasse 31  
CH - 8112 Otelfingen  
Tel.: +41 (0)44 847 1531  
Fax: +41 (0)44 847 1529  
Email: [Gerold.Brunner@ch.bosch.com](mailto:Gerold.Brunner@ch.bosch.com)

## USA

Robert Bosch LLC  
AA/SHD-NA  
Mr. Kenn Langosch  
2800 South 25th Avenue  
US - 60155-4594 - Broadview, IL  
Tel.: +1 (0)708 865 5286  
Fax: +1 (0)708 865 5360  
Email: [industrial.business@us.bosch.com](mailto:industrial.business@us.bosch.com)

## Denmark

Robert Bosch  
AA/SDK  
Mrs Eda Hojenski  
Telegrafvej 1  
DK - 2750 Ballerup  
Tel.: +45 (0)44 898 321  
Fax: +45 (0)44 898 680  
Email: [Eda.Hojenski@dk.bosch.com](mailto:Eda.Hojenski@dk.bosch.com)

## Japan

Bosch Corporation  
AA/SIS-Jp  
Mr. Matsunaga Yasuhiro  
2-3-10 Nishihon-mach Nishi-ku  
JP-550-00005 Osaka  
Tel.: +81 (3) 54 85-5849  
Fax: +81 (3) 54 85-6386  
Email: [Yasuhiro.Matsunaga@jp.bosch.com](mailto:Yasuhiro.Matsunaga@jp.bosch.com)

## Spain

Robert Bosch Espana S.A.  
AA/SIS1-IB  
Mrs Miriam Franco Estebanez  
Hermanos Garcia Noblejas 19  
ES - 28037 Madrid  
Tel.: +34 (0)91 410 4079  
Fax: +34 (0)91 327 9857  
Email: [Miriam.Franco@es.bosch.com](mailto:Miriam.Franco@es.bosch.com)

# Content

---

2	Unlimited service - Bosch electric motors
4	Parameter explanation

---

10	D.C. motors with transmission
40	– WDD - Direct drive
42	– VMC flap actuators
46	D.C. motors without transmission
60	Blowers with D.C. motors
62	Solenoid valves
66	PAD Water-circulation pumps with brushless drive
68	List of part numbers
72	Inquiry data sheet



## Notes

This catalog lists the standard parts supplied, with all the technical information normally required by design engineers to select the best motor for their particular requirements. These motors were originally designed for use in motor vehicles.

We recommend that Bosch be consulted first before you use motors for any applications other than those specified, particularly in the case of other requirements, loads, or environmental conditions. Please use the "Inquiry Sheet" for this purpose.

Subject to change.  
The current drawings quoted shall prevail.



## Unlimited service – Bosch electric motors



### The worldwide competent partner for industrial applications

As the largest manufacturer of electric motors in Europe, Bosch provides its customers with a comprehensive range of products including brushless D.C. motors and brush-type D.C. motors. Bosch electric motors are developed for the automotive industry and installed into automobiles and commercial vehicles as drives for wiping systems, engine cooling and passenger compartment air-conditioning as well as for the adjustment of windows, sliding roofs and seats.

The Bosch electric motors referred to here are permanent-magnet-excited D.C. motors. They excel on account of an excellent power/weight ratio, a broad working range and through outstanding

flexibility for adaptation to different requirements and installation situations. In addition to this they are extremely quiet and very robust (see D.C. motors without transmission).

Bosch plants around the globe operate according to the stringent, internationally-binding Bosch quality guidelines, which only permit products for series production that have been well-proven in tough endurance tests. Profit from the strongly competitive products of mass production.



**Production sites:**

1. Toluca, Mexico
2. Albion, USA
3. Campinas, Brazil
4. Castellet, Spain
5. Bühl, Germany
6. Miskolc, Hungary
7. Brits, South Africa
8. Changsha, China
9. Penang, Malaysia
10. Suzhou, China
11. Buyong, Korea
12. Clayton, Australia



**Customer orientation in development, production and sales**

**Innovative technology from the automobile industry**

- ▶ **Many million times well proven and reliable Bosch quality –**  
As a leading developer and manufacturer of automotive technology Bosch is also a mobile and experienced partner outside the automobile industry.
- ▶ **Bosch electric motors operate absolutely reliably –**  
They are available in a light and compact design, have a high output and long service life.
- ▶ **Price and performance, that match up –**  
High-volume production results in inexpensive prices.

**Individual solutions for your application**

- ▶ **The right solution for every requirement –**  
Due to a variety of different designs and sizes, the Bosch range of electric motors provides a great deal of flexibility for installation and use.  
Bosch electric motors operate in a D.C. voltage range of 12 to 24 Volt. They are also optionally available with and without Hall elements.
- ▶ **Successful application examples –**  
Power-operated hospital beds, wheel chairs, garage-door drives, lawnmowers, locking systems and output systems, electric mopeds and lots more.

**Professional customer service**

- ▶ **Engineering team for new developments –**  
Right from the very start, Bosch engineers provide their support and advice in the application engineering for D.C. motors, blowers or pumps.
- ▶ **All-encompassing customer orientation –**  
Bosch guarantees worldwide uniform production and quality standards, and availability of its products.
- ▶ **Technical information –**  
Comprehensive information on Bosch electric motors is available in our catalogue or on the available CD-ROM. Apart from this, you can also find all technical details online at [www.bosch-elektromotoren.de](http://www.bosch-elektromotoren.de).

# Parameter explanation

## Nominal values

### Nominal value

Value of a variable (e.g. voltage, current, resistance ...) according to which a motor, blower, or pump, or its characteristics and parts are specified or according to which they are designated.

### Power consumption $P_1$

$$P_1 = U \cdot I$$

$P_1$  Power consumption in W  
 $U$  Voltage in V  
 $I$  Current in A

### Output power $P_2$

For motors the output power  $P_2$  is always given.

$$P_2 = 2 \frac{\pi}{60} \cdot M \cdot n$$

$P_2$  Output power in W  
 $M$  Torque in Nm  
 $n$  Rotational speed in  $\text{min}^{-1}$

### Efficiency $\eta$

Efficiency refers to the relationship between mechanical output  $P_2$  and electrical power input  $P_1$ .

$$\eta_2 = \frac{P_2}{P_1}$$

## Fastening

- ▶ Housing fastening: By means of screws on the motor or transmission housing. Blowers are fastened in a similar manner, either to the drive motor or the air shroud.
- ▶ Flange mounting: The motor's drive-end support has a two or three-hole flange, or the front side contains three or four threaded holes for fastening.

### Example

Theoretically, a nominal voltage of 24 V and a rated current of 35 A result in a power input of  $P_1$ :

$P_1 = U_N \cdot I_N$ ;  $P_1 = 24 \text{ V} \cdot 35 \text{ A}$ ;  $P_1 = 840 \text{ W}$ .  
 This power consumption  $P_1$  and the output  $P_{2N}$  (see Fig. page 7) determined from the characteristic-curves chart are used to calculate the efficiency  $\eta$ :

$$\eta = \frac{P_{2N}}{P_1} = \frac{600 \text{ W}}{840 \text{ W}} = 0,71 = 71\%$$

### Rated torque $M_N$

The motor's rated torque is calculated from:

$$M_N = \frac{60}{2\pi} \cdot \frac{P_{2N}}{n_N}$$

$M_N$  Rated torque in Nm  
 $P_{2N}$  Rated power output in W  
 $n_N$  Rated speed in  $\text{min}^{-1}$

### Rated speed $n_N$

Rated speed refers to the speed of a motor supplied with rated voltage and driven at a rated output.

## Cooling

- ▶ Internal natural cooling: open-type design, without fan.
- ▶ Internal natural cooling: open-type design, with separate fan.
- ▶ Internal forced-air cooling: open-type design, with externally-driven fan.
- ▶ Surface natural cooling: closed design, without fan.
- ▶ Surface natural cooling: closed design, with separate fan.

### Direction of rotation

When looking at the motor's shaft end, clockwise operation is deemed to be right-handed rotation.

For motors with two shaft ends, the shaft end opposite the commutator determines the direction of rotation.

### Short-circuit values

The current consumed by the motor in case of short-circuit (when armature is braked to standstill), is the maximum current  $I_{\text{max}}$ . When a short circuit occurs, the maximum torque  $M_A$  (breakaway torque) is effective.

### IP degrees of protection

Valid for electrical equipment of road vehicles as under IEC 60529 and DIN 40050, Part 9.

- ▶ Protection of electrical equipment within housing against influence of solid foreign bodies including dust.
- ▶ Protection of electrical equipment within housing against ingress of water.
- ▶ Protection of people against touching of moving mechanical parts within housing.

## IP-code structure

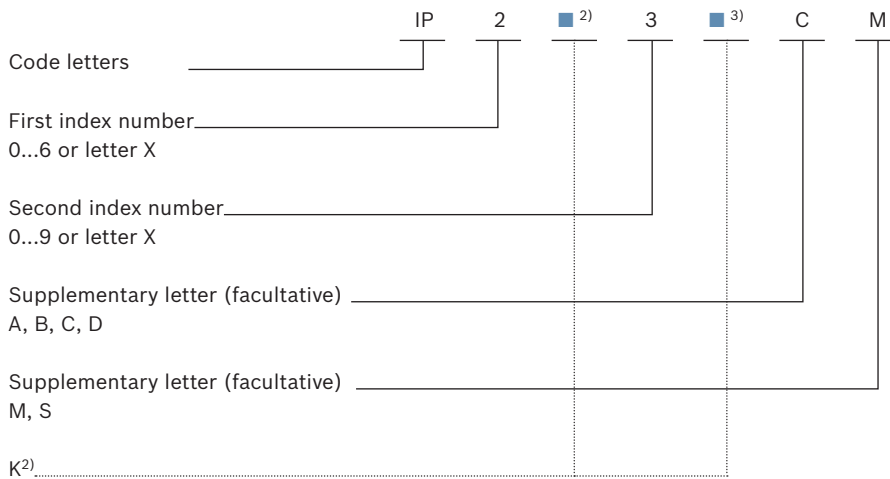

If an index number is not given, then the letter “X” must be substituted (i.e. “XX”, if both index numbers are missing).

Additional and/or supplementary letters can be omitted without any substitution:

<sup>2)</sup> The supplementary letter “K” is placed either immediately after the first index numbers 5 and 6 or immediately after the second index numbers 4, 6 and 9.

<sup>3)</sup> During the water test for example: IP16KB protection against ingress of solid foreign bodies with a diameter  $\geq 50$  mm, protection against powerful spray water at high pressure, protection against being touched by fingers.

## Explanations of IP code

1. Index number and supplementary letter K	Protection of electrical equipment against ingress of foreign bodies	People	2. Index number and supplementary letter K	Protection of electrical equipment against ingress of water	Letter (facultative)	Protection of people in event of contact with hazardous parts	Letter (facultative)	
0	Not protected	Not protected	0	Not protected	A	Protection against contact with back of hand	M	Motion of moving parts Teile <sup>3)</sup>
1	Protection against foreign bodies $\varnothing \geq 50$ mm	Protection against contact with back of hand	1	Protection against vertical droplets	B	Protection against contact with fingers	S	Standstill of moving parts Teile <sup>3)</sup>
2	Protection against foreign bodies $\varnothing \geq 12.5$ mm	Protection against contact with fingers	2	Protection against droplets, 15° Inclination	C	Protection against contact with tools		
3	Protection against foreign bodies $\varnothing \geq 2.5$ mm	Protection against contact with tools	3	Protection against spray water	D	Protection against contact with wire		
4	Protection against foreign bodies $\varnothing \geq 1.0$ mm	Protection against contact with wire	4	Protection against spray water				
5K	Dust-protected	Protection against contact with wire	4K	Protection against spray water with increased pressure				
6K	Dust-proof	Protection against contact with wire	5	Protection against spray water				
			6	Protection against powerful spray water				
			6K	Protection against powerful spray water with increased pressure				
			7	Protection against temporary immersion				
			8	Protection against permanent immersion				
			9K	Protection against high pressure/vapor pressure cleaning				



**Operating modes** (VDE 0530)

**Continuous operation S 1**

Operation with constant load condition, the duration of which is sufficient to reach the thermal steady-state condition.

**Parameters for curve inspection**

- $P_1$  Power input
- $P_V$  Power loss
- $\vartheta$  Temperature
- $\vartheta_{max}$  Highest temperature
- $t_B$  Load period
- $t_r$  Relative on period (as percentage)
- $t_S$  Duration
- $t_{st}$  Standstill period

**Short-term operation S 2**

Operation with constant load condition, which does not last long enough however to enable the thermal steady-state condition to be reached, and a subsequent pause, which lasts long enough for the motor temperature not to deviate more than 2 K from the coolant temperature.

Example: S 2 – 60 min  
(The stated time refers to 60 minutes of operation at normal rating)

**Intermittent operation S 3**

Operation, comprised of a sequence of similar cycles, each of which encompasses a time with constant load and a pause, whereby the startup current does not exert any perceptible influence on heating.

Example: S 3 – 10%  
(Stated percentage refers to on period)

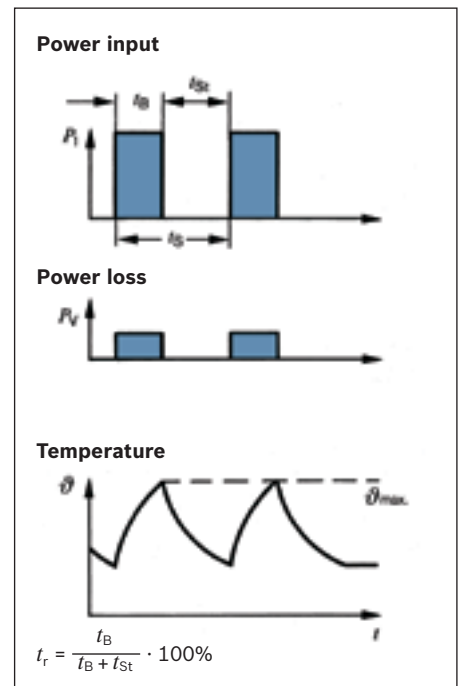
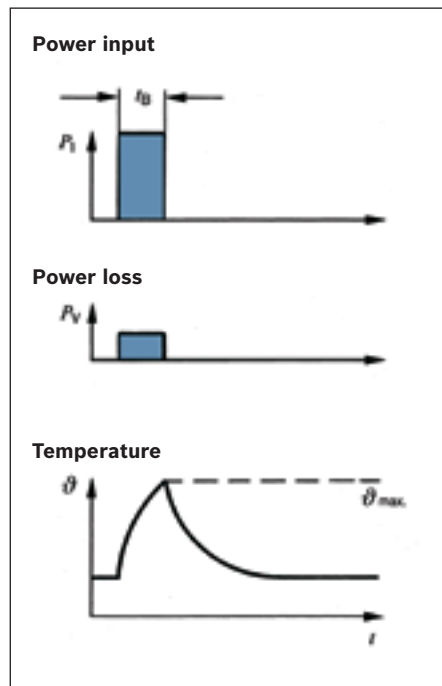
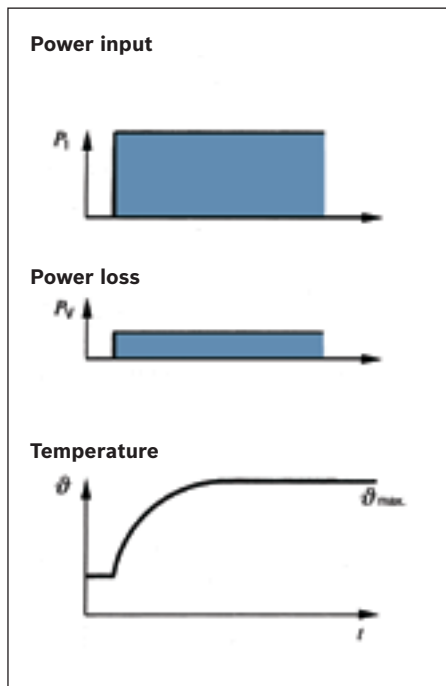

Symbols		
Permanent- (magnet) excited D.C. motor		
Interference- suppression component Throttle		
Interference- suppression component Capacitor		
	Varistor disk	
	Resistance	
	Thermoswitch	
	Limit shutoff	
	Varistor (voltage-dependent resistor)	
	Bridge rectifier	

## Characteristic curves

With a specified working point of 160 Ncm one plots a vertical line to the torque axis. The intersecting points of these vertical lines with the various characteristic curves result in the operating data for the rated speed  $n_N$ , rated current  $I_N$  and mechanical output  $P_{2N}$ .

Explanation of characteristic curve evaluation

AP Working point

$M$  Torque

$P_2$  Power input

$I$  Current

$n$  Rotational speed

Example:

Given:  $M_N = 160$  Ncm.

Found:  $n_N = 3.800$  rpm ( $\text{min}^{-1}$ ).

$P_{2N} = 636$  W and  $I_N = 35$  A.

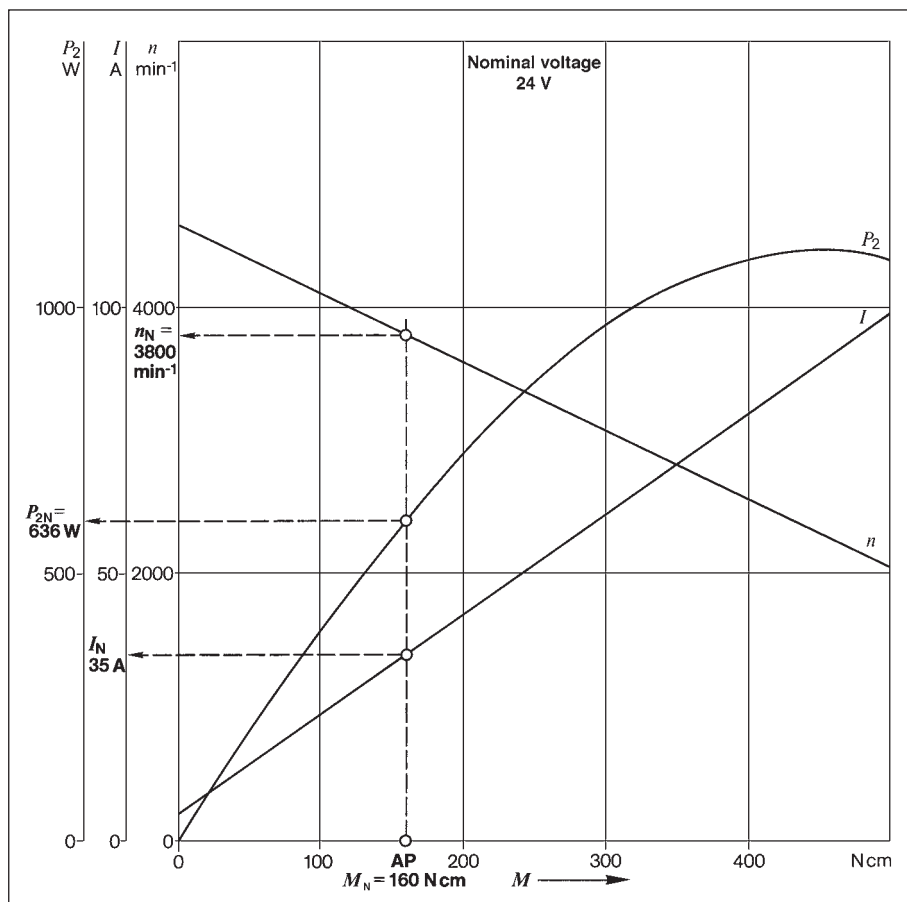

## CE-Identification and manufacturer declaration in accordance with EU directive

As under the EU Directive all electrically-powered machines, devices and systems, which are manufactured, imported and sold within the borders of the European Union must have a CE-label attached to them. The EU Directive also includes the following individual guidelines, which are of significance for motor users.

### 1. Machine Directive

It is valid for self-contained operational machines or any interlinking of machines to form integral systems.

It is not valid for machine components however, such as, for example, electrical control systems or electric motors which have no independent function.

The entire machine or system must always comply with the Directive.

### 2. Low-voltage Directive

It is valid and is to be applied for all electric motors as from a low-voltage limit of 75 V for D.C. voltage and 50 V for A.C. voltage and higher.

Because the electric motors listed in this catalogue are designed for rated voltages of up to maximum 24 V, they are not governed by this Directive.

### 3. EMC Directive

This Directive is valid for all electrical and electronic devices, installations and systems. However, this Directive is also valid for complex components such as, e.g. electric motors, although this only applies where they are openly available for purchase by the public. The electric motors listed in this catalogue are solely shipped as supplied parts or replacement parts, and are not subject to § 5 paragraph 5 of the EMC Act regarding a mandatory CE label.

The limits for the relaying and the radiation of high-frequency interference are specified in EN 55014 of the EMC Act.

Because of the previously-mentioned reasons, Bosch electric motors are on no account subject to mandatory CE labeling.

We will gladly assist you with information in all matters relating to the acceptance of your application.

# Motors with Hall sensor

## Hall effect

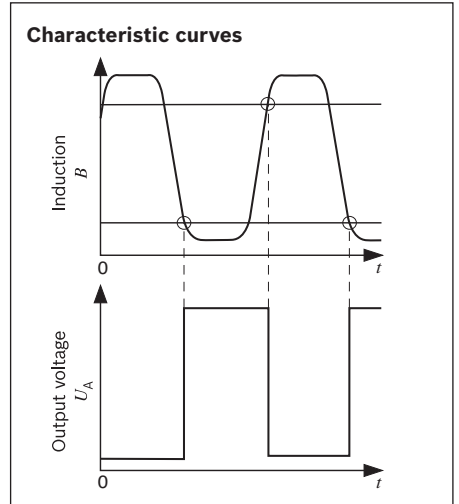
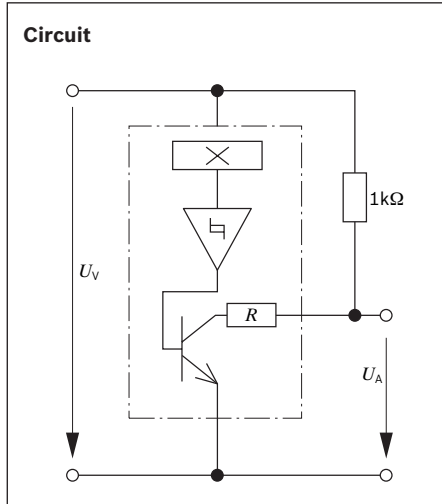
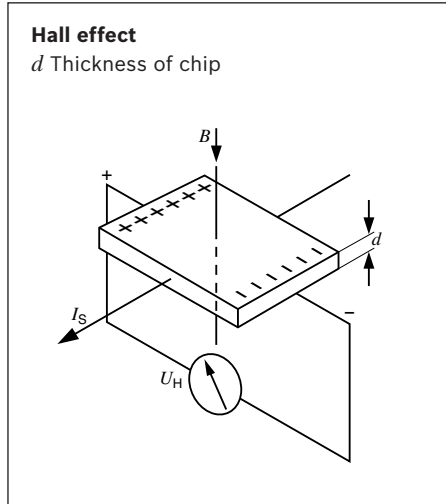

If a current  $I_s$  flows through a chip, a Hall voltage  $U_H$  is generated transverse to the direction of the current, the size of which is proportional to the magnetic induction  $B$  (vertical to  $I_s$ ) and the current  $I_s$ . The Hall voltage  $U_H$  is made up of:

$$U_H = R_H \cdot \frac{I_s \cdot B}{d}$$

$R_H$  Hall-constant factor

Since the resulting Hall voltages are extremely small, they are amplified. When using silicon Hall elements, the circuit for signal processing (e.g. a Schmitt trigger with subsequent driver) are integrated directly onto the same chip. This component is then designated a Hall-IC. The output is a transistor with open collector, with which a switching function is realized.

Permanently connected to the armature shaft is a magnetic ring, the magnetic field of which permeates the Hall element. When the armature shaft rotates, the magnetomotive-force direction in the Hall element changes. The output transistor is then either switched through or open.

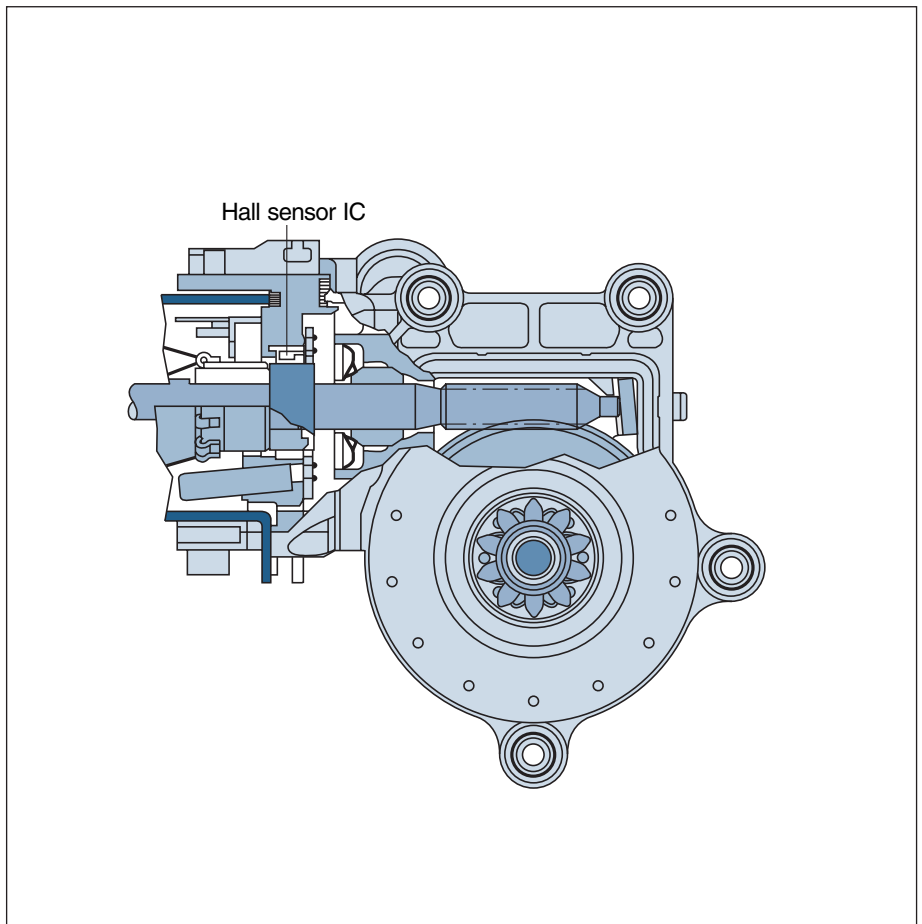



**Hall-effect applications in D.C. motors**

By counting the generated output-voltage pulses, one can determine the number of rotations and thus the speed. If the rotational motion is converted into a linear motion, it then becomes possible to monitor the adjustment travel exactly. If there are two Hall generators installed offset to each other at a specific angle  $\alpha$  in a motor, then the direction of rotation can also be determined.

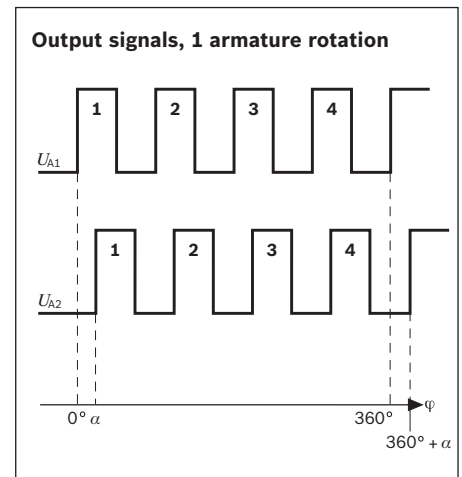
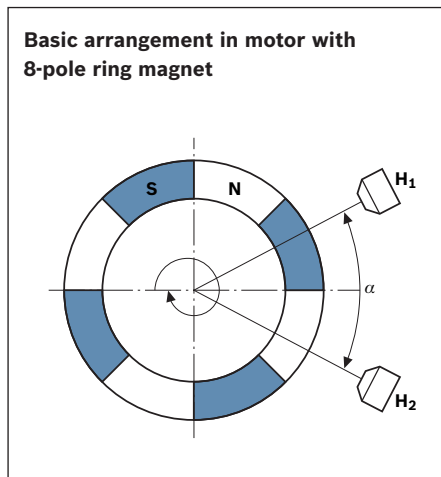
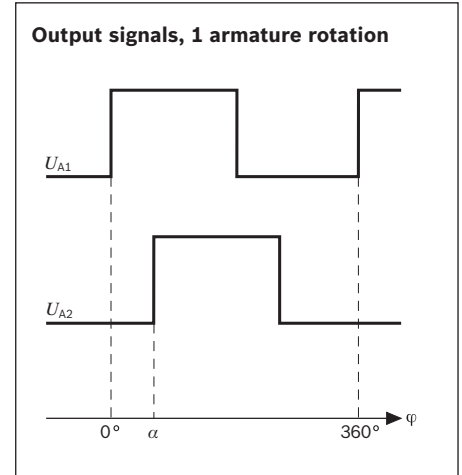
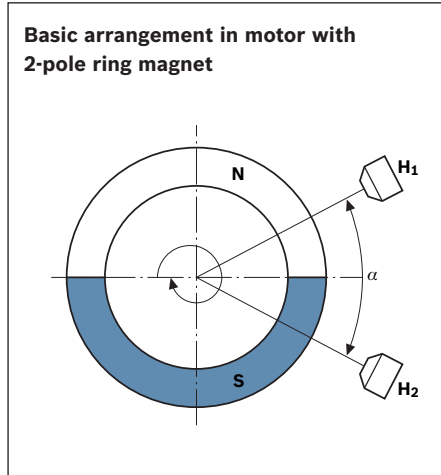

**Basic arrangement in motor**

- $H_1, H_2$  Hall generator
- N North pole
- S South pole
- $\alpha$  Angle between the two Hall generators

**Output signals**

- $U_{A1}$  Output voltage of first Hall generator
- $U_{A2}$  Output voltage of second Hall generator
- $\alpha$  Angle between the two Hall generators
- $\varphi$  Rotational angle

## D.C. motors with transmission



### Product features

- ▶ Wide range of permanently-excited motor-and-gear assemblies
- ▶ D.C. voltage range from 12 to 24 Volt
- ▶ Available with and without self-locking feature
- ▶ Breakaway torques from 1 Nm to 25 Nm
- ▶ Speed range from 16 to 700 rpm (min<sup>-1</sup>)
- ▶ Available with and without Hall sensors

### Advantages for your application

- ▶ A multitude of different sizes and designs for greater flexibility
- ▶ Robust and reliable quality, well-proven millions of times over in automobiles
- ▶ High reliability
- ▶ Favorable price/performance ratio

Bosch electric motors with transmission provide fitting solutions for almost every application. They provide a wide range of performance and are highly versatile in their application. The new generation of Bosch adjustment motors have a compact design and have been optimized in terms of installation space and weight. In addition to this, they are exceptionally quiet and highly robust.

The desired speed can easily be regulated by changing the voltage. The direction of rotation can be inverted by changing over +/- . Maximum torque is available during the startup phase.

### Application examples

#### Automotive technology:

Flap positioning for climate control, air proportioning and distribution, wiper motors, power-window motors, seat-adjustment motors, adjustment motors

#### Industrial applications:

Control motors, garage-door drives, locking systems, medical technology etc.



# AHC

## 12 V 10,4 W

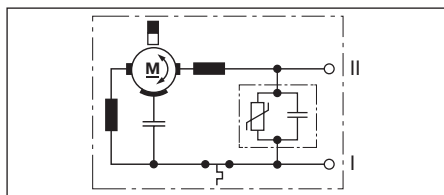

Part number	<b>0 390 201 948</b>
Nominal voltage	$U_N$ 12 V
Nominal power	$P_N$ 10,4 W
Nominal current	$I_N$ < 5 A
Maximum current	$I_{max}$ 17 A
Nominal speed	$n_N$ 22 min <sup>-1</sup>
Nominal torque	$M_N$ 4,5 Nm
Breakaway torque	$M_A$ > 16 Nm
Reduction	i 119,5 : 1
Direction of rotation	L/R
Type of duty	S 2 - 5 min
Degree of protection	IP 50
Weight	approx. 0,63 kg

Clockwise: II on (+)  
 Anti-clockwise: I on (+)

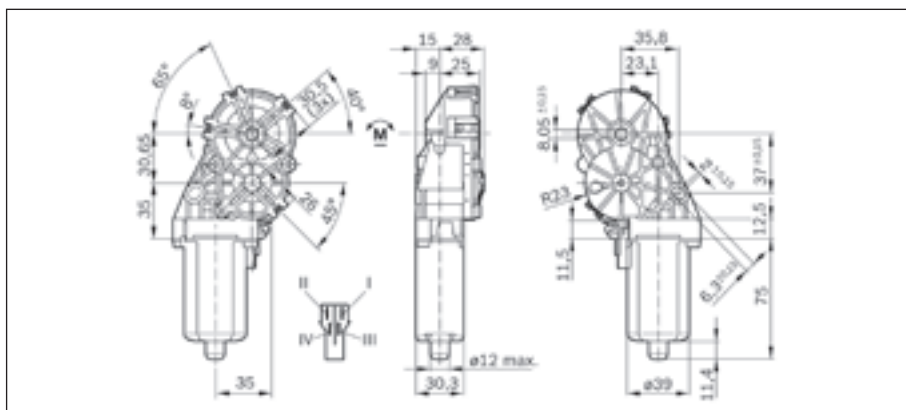
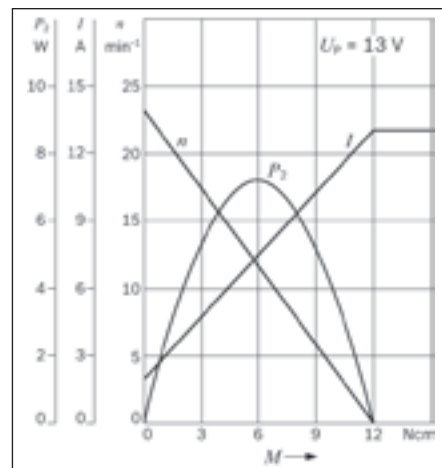

# AHC

## with Hall sensor

## 12 V 10,4 W

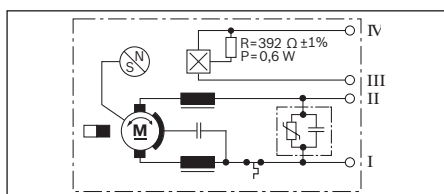

Part number	<b>0 390 201 949</b>
Nominal voltage	$U_N$ 12 V
Nominal power	$P_N$ 10,4 W
Nominal current	$I_N$ < 5 A
Maximum current	$I_{max}$ 17 A
Nominal speed	$n_N$ 22 min <sup>-1</sup>
Nominal torque	$M_N$ 4,5 Nm
Breakaway torque	$M_A$ > 16 Nm
Reduction	i 119,5 : 1
Direction of rotation	L/R
Type of duty	S 2 - 5 min
Degree of protection	IP 50
Weight	approx. 0,63 kg

Clockwise: II on (+)  
 Anti-clockwise: I on (+)

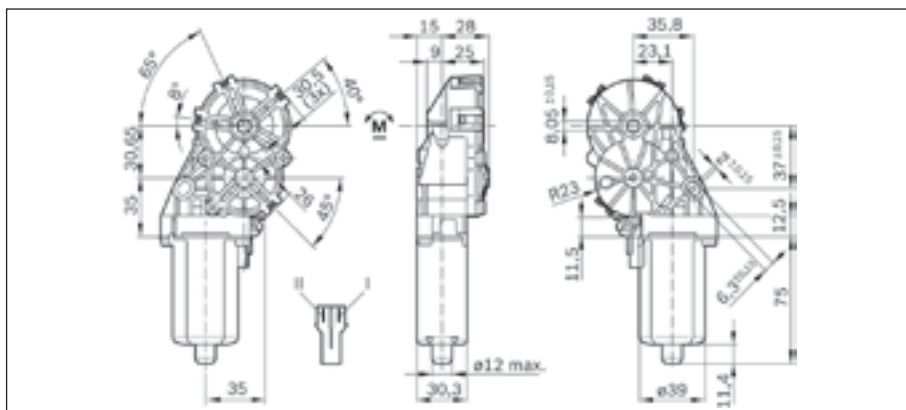
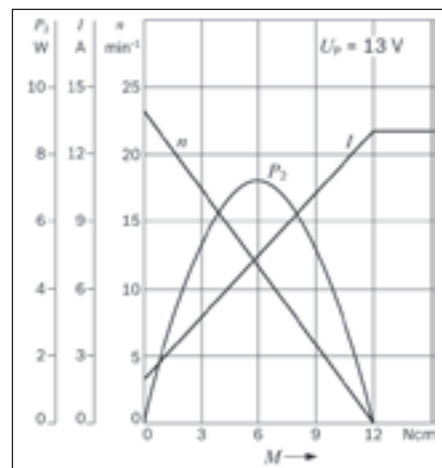





# AHC

## 12 V 29 W

Part number	<b>0 390 201 901</b>
mirror-image	<b>0 390 201 913</b>
Nominal voltage	$U_N$ 12 V
Nominal power	$P_N$ 29 W
Nominal current	$I_N$ < 7,5 A
Maximum current	$I_{max}$ 22 A
Nominal speed	$n_N$ 700 min <sup>-1</sup>
Nominal torque	$M_N$ 0,4 Nm
Breakaway torque	$M_A$ > 1,4 Nm
Reduction	i 27 : 4
Direction of rotation	L/R
Type of duty	S 2 - 5 min
Degree of protection	IP 50
Weight	approx. 0,40 kg

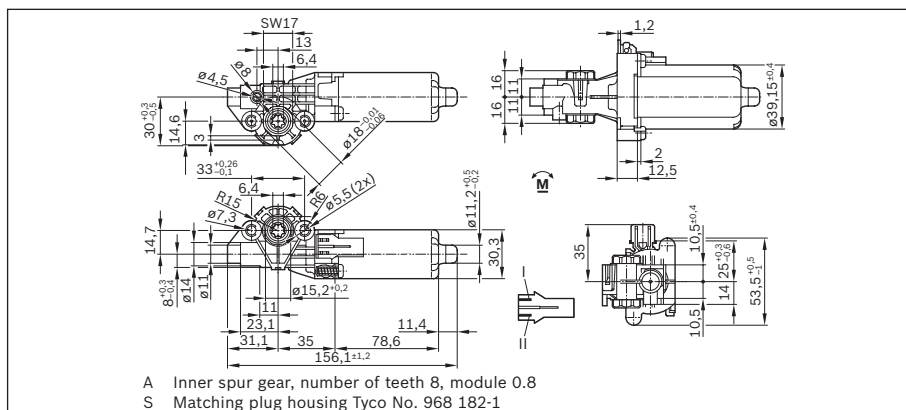
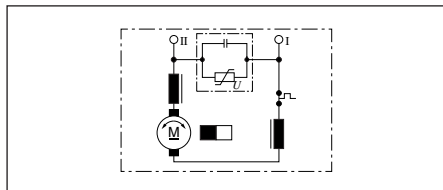
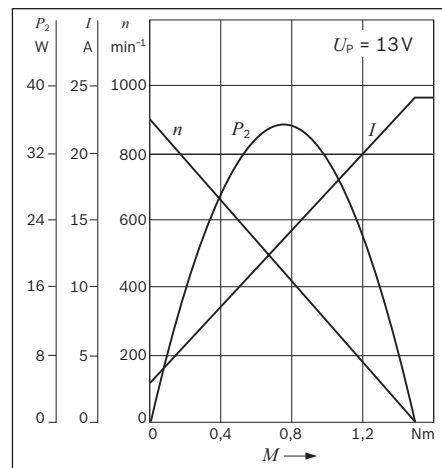

# AHC

## with Hall sensor

## 12 V 21 W

Part number	<b>0 390 201 902</b>
mirror-image	<b>0 390 201 914</b>
Nominal voltage	$U_N$ 12 V
Nominal power	$P_N$ 21 W
Nominal current	$I_N$ < 6 A
Maximum current	$I_{max}$ 17 A
Nominal speed	$n_N$ 675 min <sup>-1</sup>
Nominal torque	$M_N$ 0,3 Nm
Breakaway torque	$M_A$ > 1 Nm
Reduction	i 27 : 4
Direction of rotation	L/R
Type of duty	S 2 - 5 min
Degree of protection	IP 50
Weight	approx. 0,33 kg

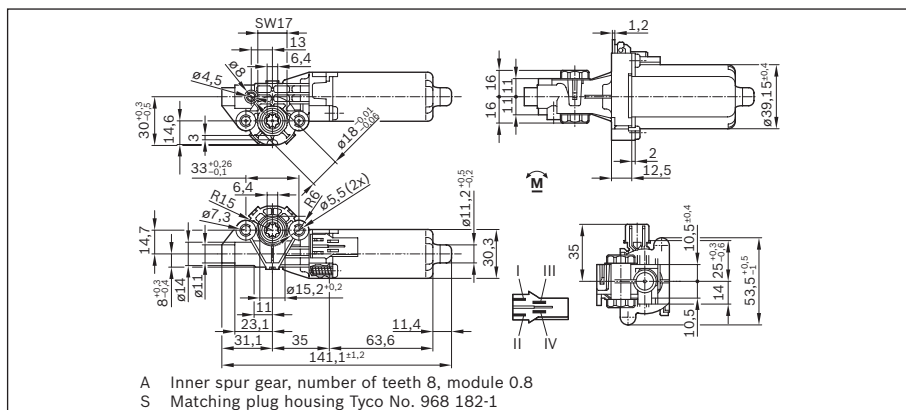
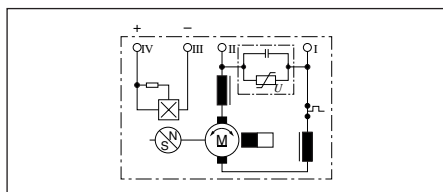
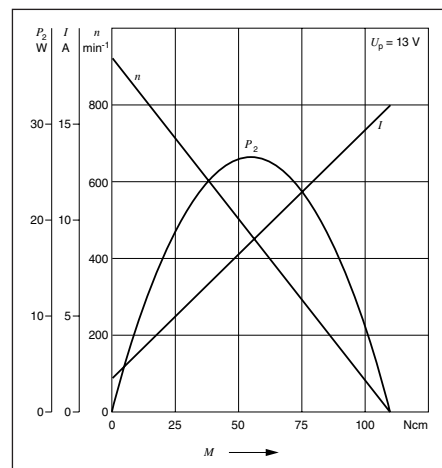

# AHC

## with Hall sensor

### 12 V 29 W

Part number	<b>0 390 201 903</b>
mirror-image	<b>0 390 201 915</b>
Nominal voltage	$U_N$ 12 V
Nominal power	$P_N$ 29 W
Nominal current	$I_N$ < 7,5 A
Maximum current	$I_{max}$ 22 A
Nominal speed	$n_N$ 700 min <sup>-1</sup>
Nominal torque	$M_N$ 0,4 Nm
Breakaway torque	$M_A$ > 1,2 Nm
Reduction	i 27 : 4
Direction of rotation	L/R
Type of duty	S 2 - 5 min
Degree of protection	IP 50
Weight	approx. 0,40 kg

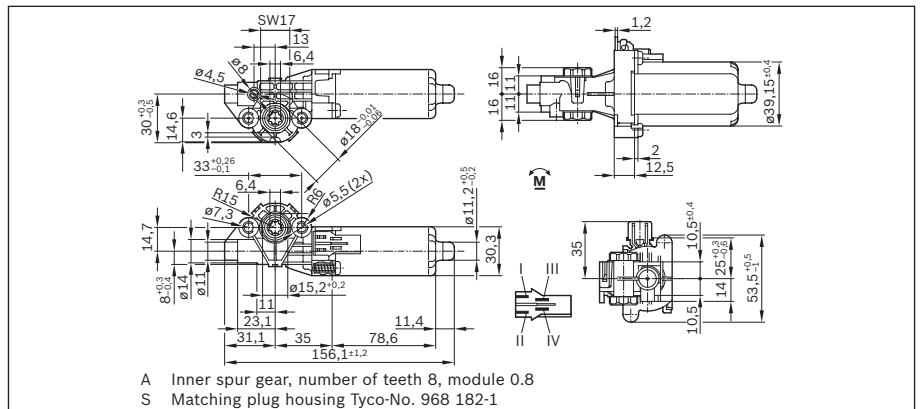
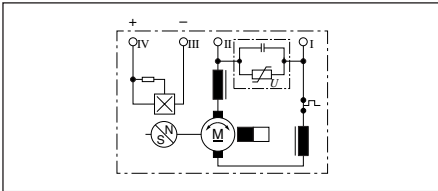
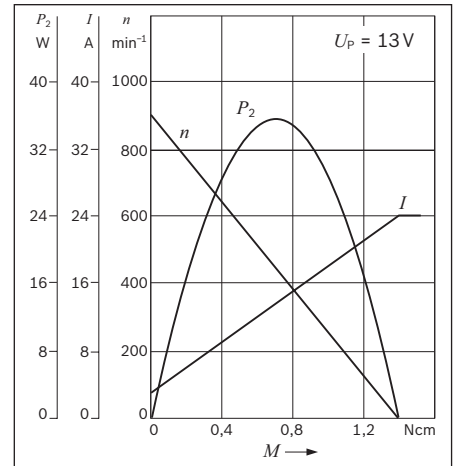

# AHC

### 12 V 8 W

Part number	<b>0 390 201 918</b>
Nominal voltage	$U_N$ 12 V
Nominal power	$P_N$ 8 W
Nominal current	$I_N$ < 8 A
Maximum current	$I_{max}$ 23,5 A
Nominal speed	$n_N$ 26 min <sup>-1</sup>
Nominal torque	$M_N$ 3 Nm
Breakaway torque	$M_A$ > 19 Nm
Reduction	i 185,5 : 1
Direction of rotation	L/R
Type of duty	S 2 - 5 min
Degree of protection	IP 50
Weight	approx. 0,45 kg

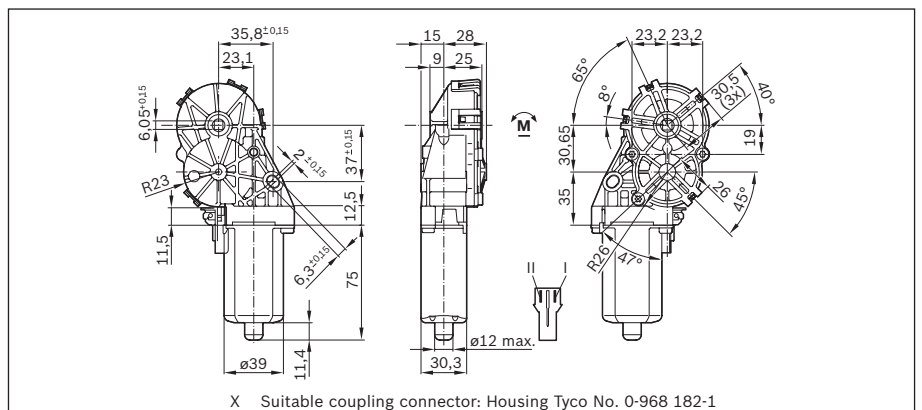
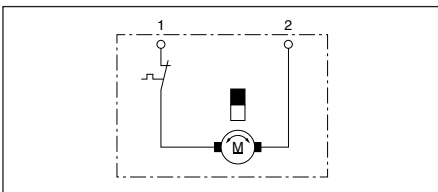
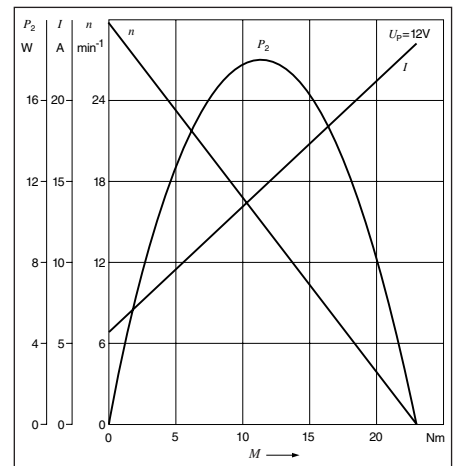

# AHC

## with Hall sensor

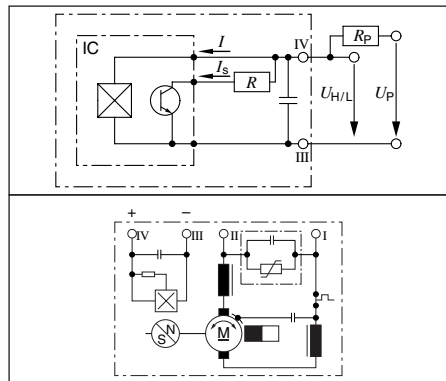

### 12 V 8 W

Part number	<b>0 390 201 925</b>
Nominal voltage	$U_N$ 12 V
Nominal power	$P_N$ 8 W
Nominal current	$I_N$ < 8 A
Maximum current	$I_{max}$ 23,5 A
Nominal speed	$n_N$ 26 min <sup>-1</sup>
Nominal torque	$M_N$ 3 Nm
Breakaway torque	$M_A$ > 19 Nm
Reduction	i 185,5 : 1
Direction of rotation	L/R
Type of duty	S 2 - 5 min
Degree of protection	IP 50
Weight	approx. 0,45 kg

Clockwise: (+) to II, (-) to I  
 Anti-clockwise: (+) to I, (-) to II  
 A square-wave period is generated for each turn of the armature.

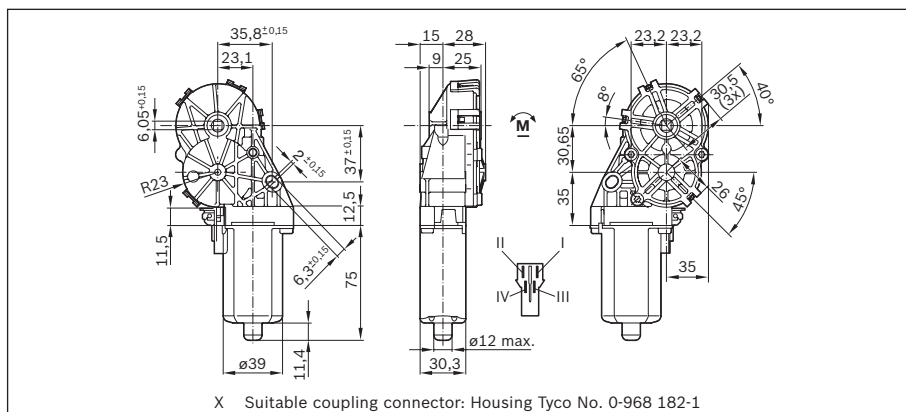
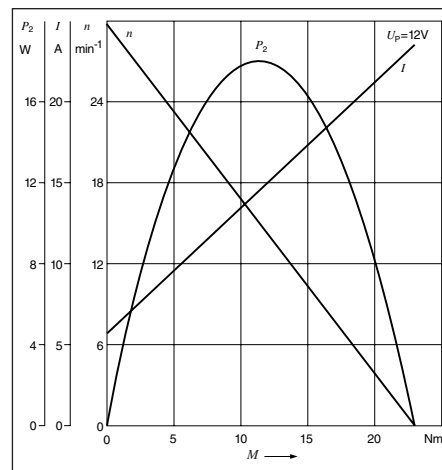

# AHC

## with Hall sensor

### Actuator motor with spindle

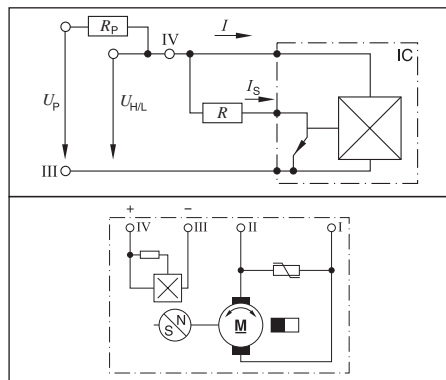

### 12 V

Part number	<b>0 390 201 927</b>
Nominal voltage	$U_N$ 12 V
Nominal current	$I_N$ < 4 A
Maximum current	$I_{max}$ 17 A
Nominal force	$F_N$ 500 N
Maximum force	$F_{max}$ 2800 N
Adjustment speed	$v_N$ 5 mm/s
Degree of protection	IP 50
Weight	approx. 0,55 kg

Clockwise: (+) to II, (-) to I  
 Anti-clockwise: (+) to I, (-) to II  
 A square-wave period is generated for each turn of the armature.

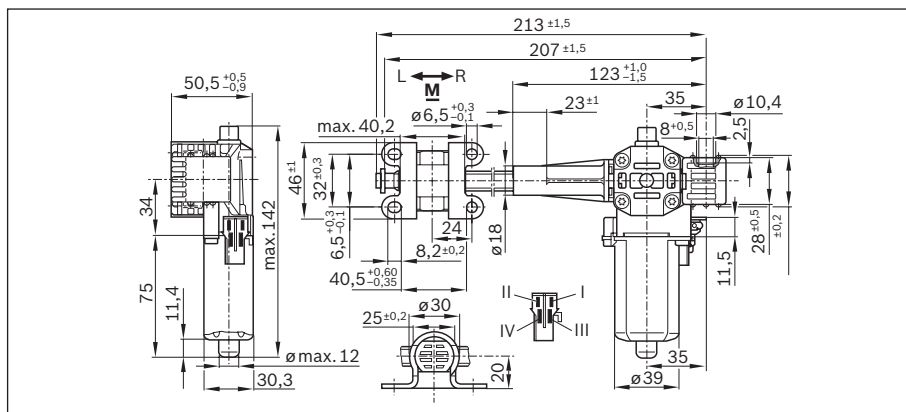
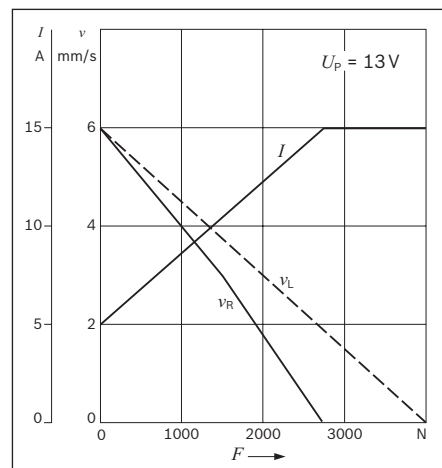

# AHC

## Actuator motor with spindle

### 12 V

Part number	<b>0 390 201 941</b>
Nominal voltage	$U_N$ 12 V
Nominal current	$I_N$ < 6 A
Maximum current	$I_{max}$ 23 A
Nominal force	$F_N$ 500 N
Maximum force	$F_{max}$ 3200 N
Adjustment speed	$v_N$ 7 mm/s
Degree of protection	IP 50
Weight	approx. 0,54 kg

Clockwise: (+) to I  
Anti-clockwise: (+) to II

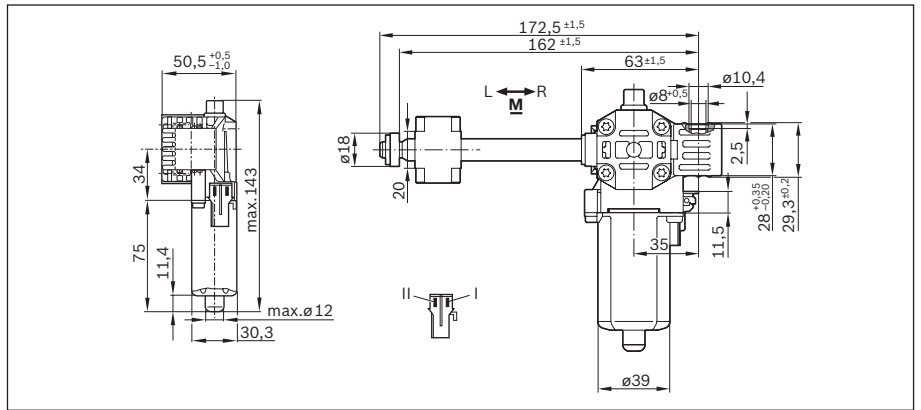
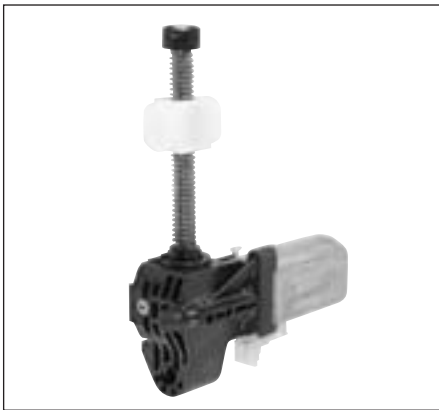
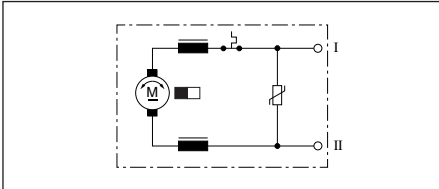
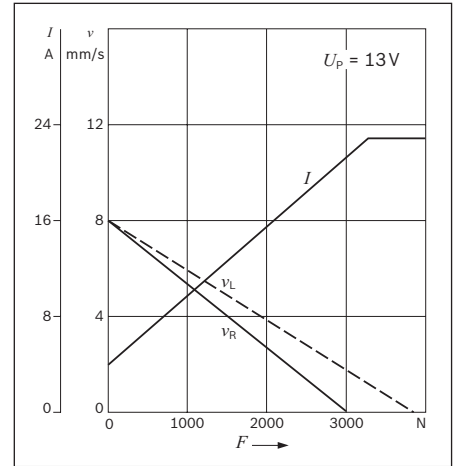

# AHC

### 12 V 8 W

Part number	<b>0 390 201 944</b>
Nominal voltage	$U_N$ 12 V
Nominal power	$P_N$ 8 W
Nominal current	$I_N$ < 8 A
Maximum current	$I_{max}$ 24 A
Nominal speed	$n_N$ 26 min <sup>-1</sup>
Nominal torque	$M_N$ 3 Nm
Breakaway torque	$M_A$ > 19 Nm
Reduction	i 185,5 : 1
Direction of rotation	L/R
Type of duty	S 2 - 5 min
Degree of protection	IP 50
Weight	approx. 0,45 kg

Clockwise: (+) to 1  
Anti-clockwise: (+) to 2

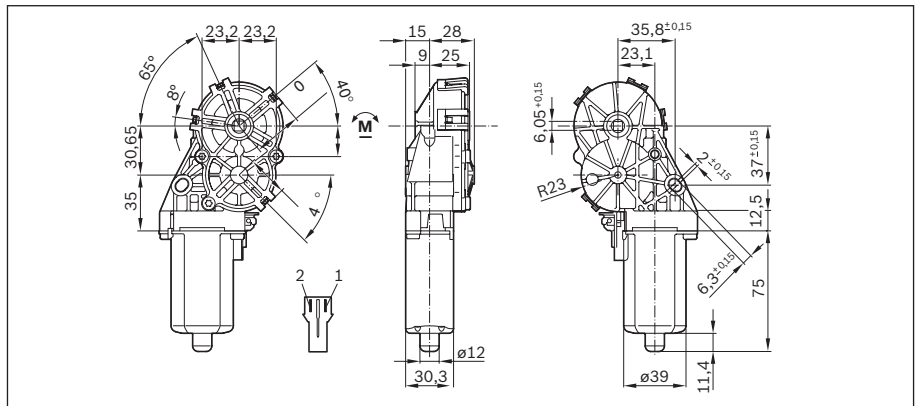
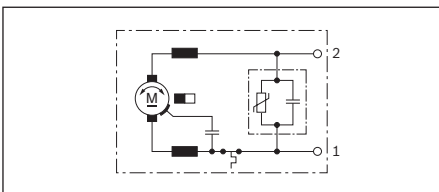
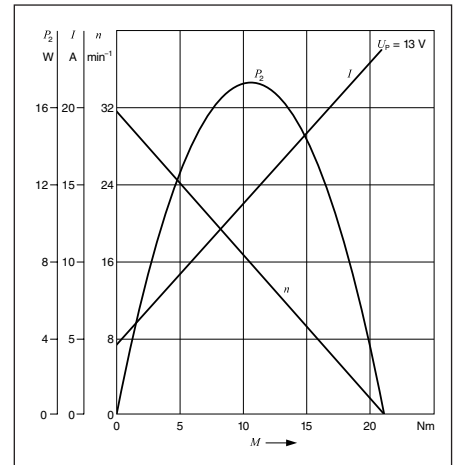



# AHC

## with Hall sensor

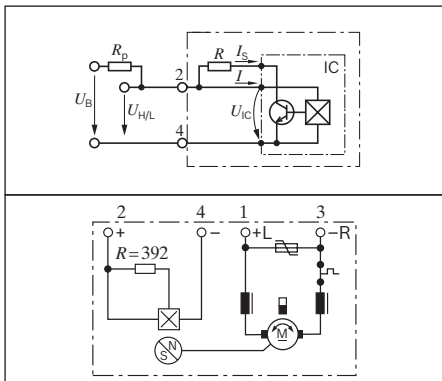

### 12 V 6.3 W

Part number	<b>0 390 201 972</b>
Nominal voltage	$U_N$ 12 V
Nominal power	$P_N$ 6,3 W
Nominal current	$I_N$ < 6 A
Maximum current	$I_{max}$ 15 A
Nominal speed	$n_N$ 20 min <sup>-1</sup>
Nominal torque	$M_N$ 3 Nm
Breakaway torque	$M_A$ > 17,5 Nm
Reduction	$i$ 185,5 : 1
Direction of rotation	L/R
Type of duty	S 2 - 5 min
Degree of protection	IP 50
Weight	approx. 0,49 kg

Clockwise: (+) to 1  
Anti-clockwise: (+) to 3

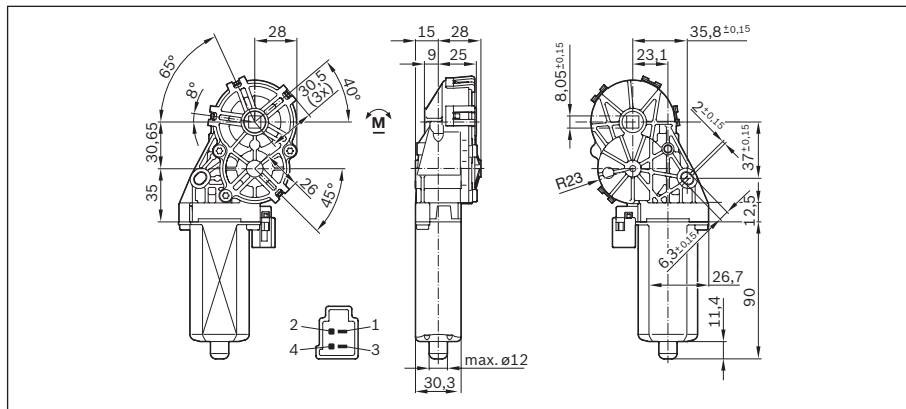
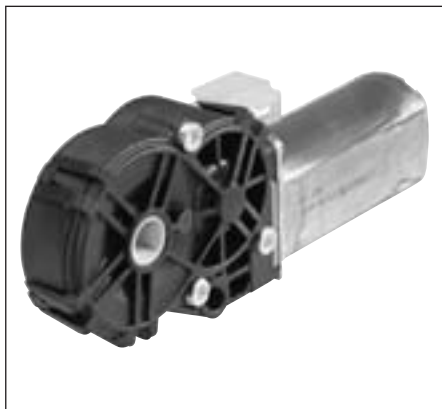
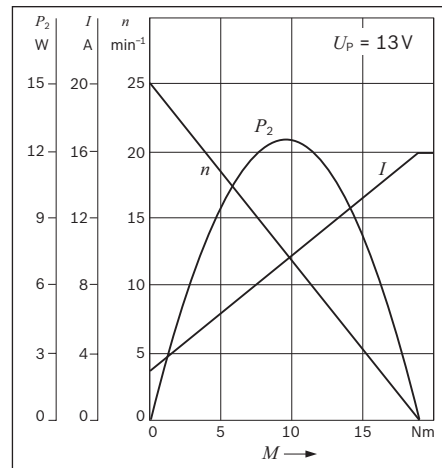

# AHC

### 12 V 6.3 W

Part number	<b>0 390 201 973</b>
Nominal voltage	$U_N$ 12 V
Nominal power	$P_N$ 6,3 W
Nominal current	$I_N$ < 6 A
Maximum current	$I_{max}$ 15 A
Nominal speed	$n_N$ 20 min <sup>-1</sup>
Nominal torque	$M_N$ 3 Nm
Breakaway torque	$M_A$ > 17,5 Nm
Reduction	$i$ 185,5 : 1
Direction of rotation	L/R
Type of duty	S 2 - 5 min
Degree of protection	IP 50
Weight	approx. 0,49 kg

Clockwise: (+) to 1  
Anti-clockwise: (+) to 3

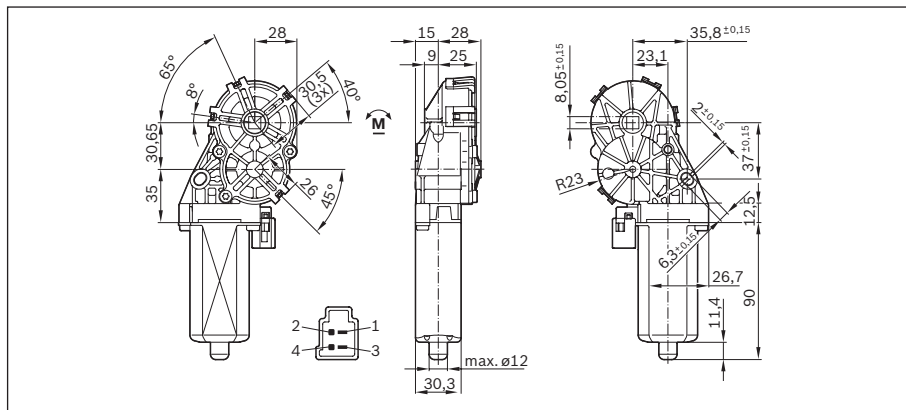
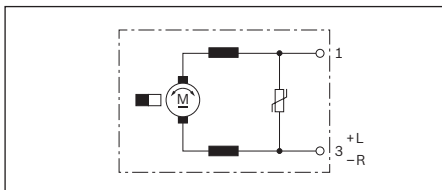
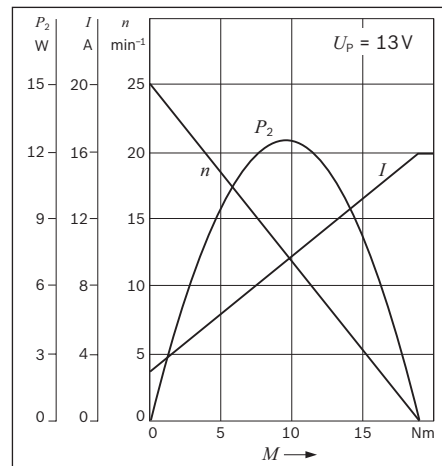



# AHC

## 12 V 6.3 W

Part number	<b>0 390 201 999</b>
Nominal voltage	$U_N$ 12 V
Nominal power	$P_N$ 6,3 W
Nominal current	$I_N$ < 6 A
Maximum current	$I_{max}$ 15 A
Nominal speed	$n_N$ 20 min <sup>-1</sup>
Nominal torque	$M_N$ 3 Nm
Breakaway torque	$M_A$ > 19 Nm
Reduction	i 185,5 : 1
Direction of rotation	L/R
Type of duty	S 2 - 5 min
Degree of protection	IP 50
Weight	approx. 0,49 kg

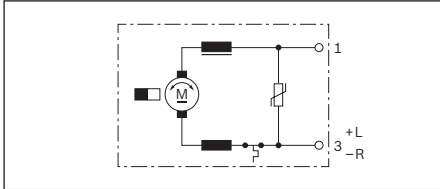
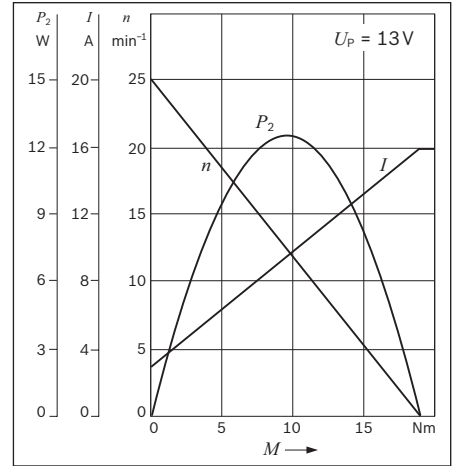

Clockwise: (+) to 1  
Anti-clockwise: (+) to 3

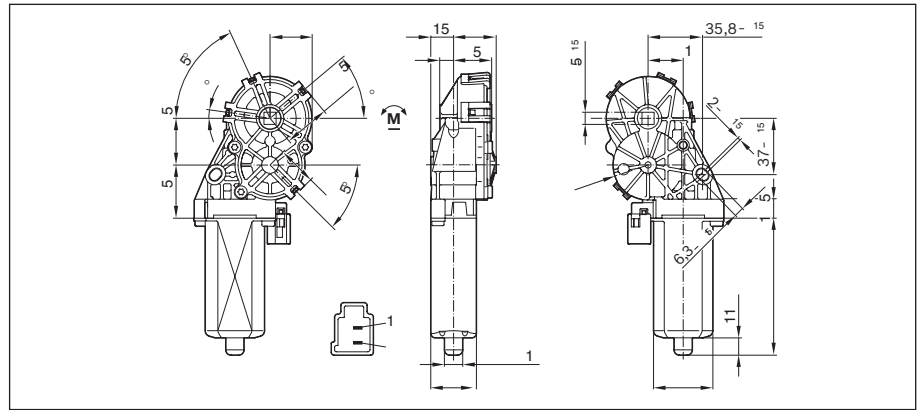
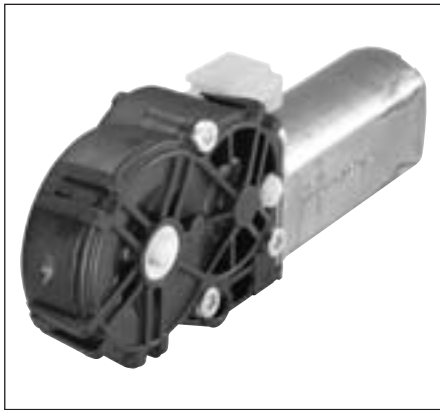

# AHC

## 12 V 5 W

Part number	<b>0 390 203 224</b>
mirror-image	<b>0 390 203 225</b>
Nominal voltage	$U_N$ 12 V
Nominal power	$P_N$ 5 W
Nominal current	$I_N$ < 4,5 A
Maximum current	$I_{max}$ 14 A
Nominal speed	$n_N$ 16 min <sup>-1</sup>
Nominal torque	$M_N$ 3 Nm
Breakaway torque	$M_A$ > 19 Nm
Reduction	i 217 : 1
Direction of rotation	L/R
Type of duty	S 2 - 5 min
Degree of protection	IP 50
Weight	approx. 0,50 kg

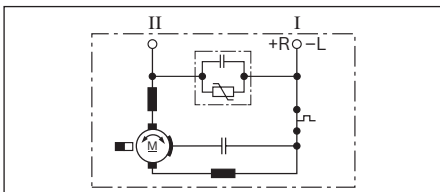
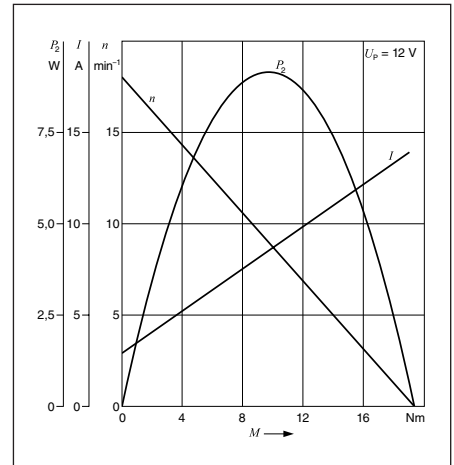

Clockwise: (+) to II  
Anti-clockwise: (+) to I

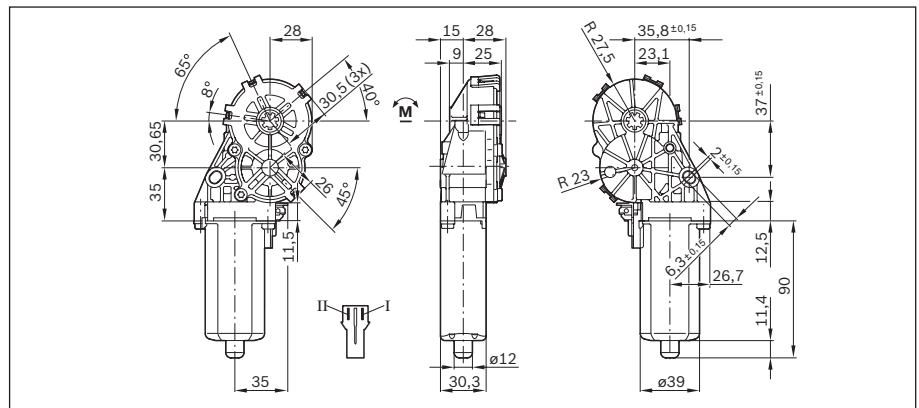



# AHC

## 12 V 11 W

Part number	<b>0 390 203 306</b>
mirror-image	<b>0 390 203 307</b>
Nominal voltage	$U_N$ 12 V
Nominal power	$P_N$ 11 W
Nominal current	$I_N$ < 6 A
Maximum current	$I_{max}$ 14 A
Nominal speed	$n_N$ 17 min <sup>-1</sup>
Nominal torque	$M_N$ 6 Nm
Breakaway torque	$M_A$ > 23,9 Nm
Reduction	i 217 : 1
Direction of rotation	R/L
Type of duty	S 2
Degree of protection	IP 50
Weight	approx. 0,50 kg

Clockwise: (+) to II, (-) to I  
 Anti-clockwise: (+) to I, (-) to II

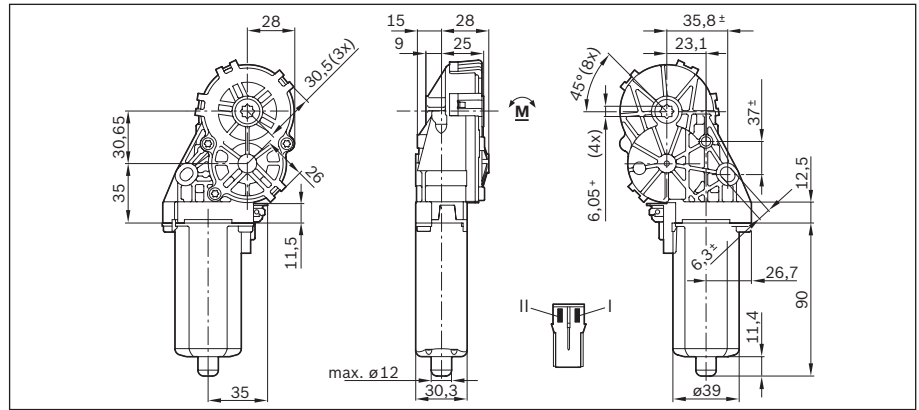
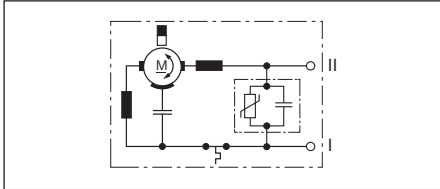
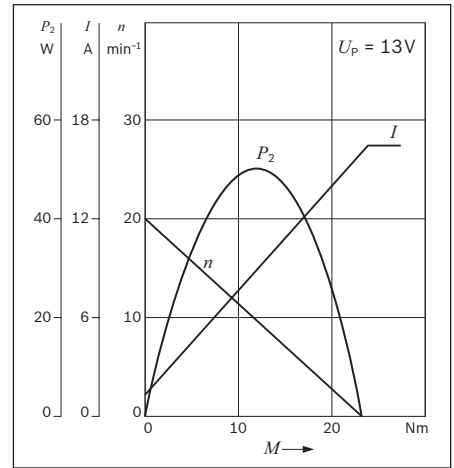

# AHC

## with Hall sensor

## 12 V 11 W

Part number	<b>0 390 203 308</b>
mirror-image	<b>0 390 203 309</b>
Nominal voltage	$U_N$ 12 V
Nominal power	$P_N$ 11 W
Nominal current	$I_N$ < 6 A
Maximum current	$I_{max}$ 14 A
Nominal speed	$n_N$ 17 min <sup>-1</sup>
Nominal torque	$M_N$ 6 Nm
Breakaway torque	$M_A$ > 23,9 Nm
Reduction	i 217 : 1
Direction of rotation	R/L
Type of duty	S 2
Degree of protection	IP 50
Weight	approx. 0,50 kg

Clockwise: (+) to II, (-) to I  
 Anti-clockwise: (+) to I, (-) to II

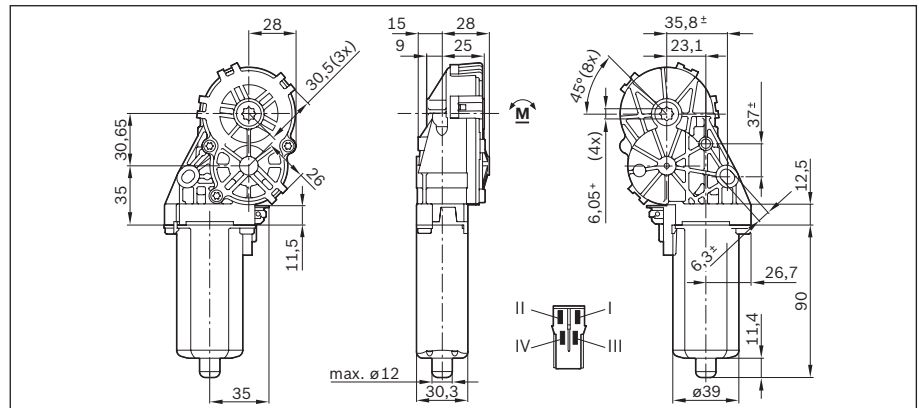
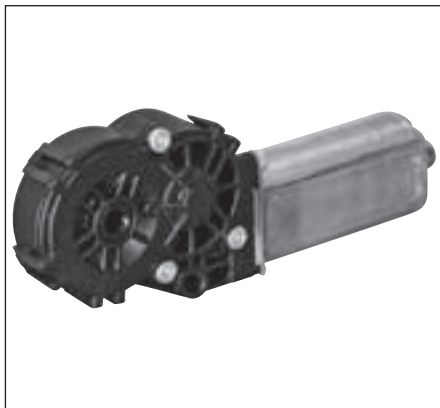
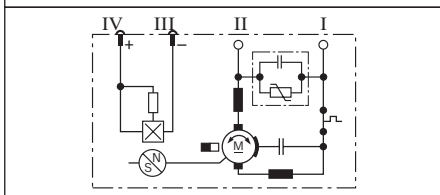
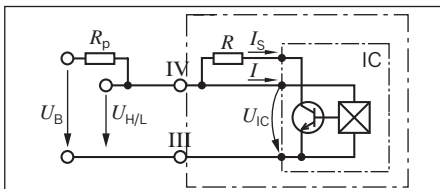
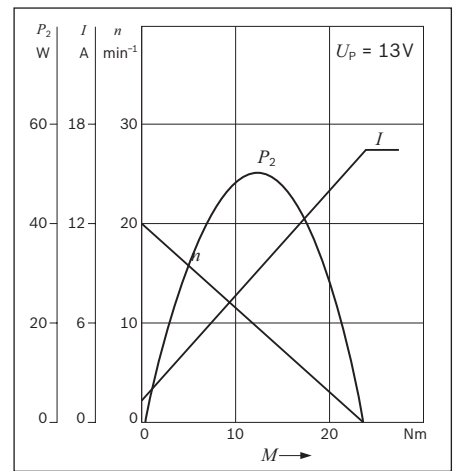



# AHC

## 24 V 5 W

Part number	<b>0 390 203 310</b>
mirror-image	<b>0 390 203 311</b>
Nominal voltage	$U_N$ 24 V
Nominal power	$P_N$ 5 W
Nominal current	$I_N$ < 2,3 A
Maximum current	$I_{max}$ 7 A
Nominal speed	$n_N$ 16 min <sup>-1</sup>
Nominal torque	$M_N$ 3 Nm
Breakaway torque	$M_A$ > 23,3 Nm
Reduction	i 217 : 1
Direction of rotation	L/R
Type of duty	S 2 - 5 min
Degree of protection	IP 50
Weight	approx. 0,50 kg

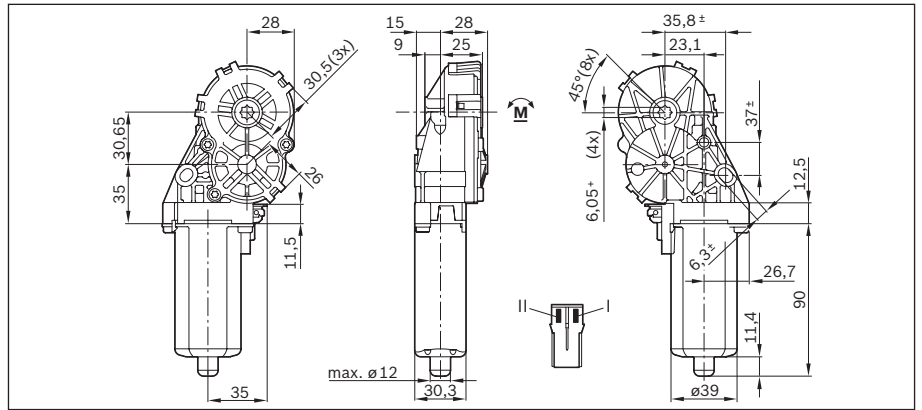
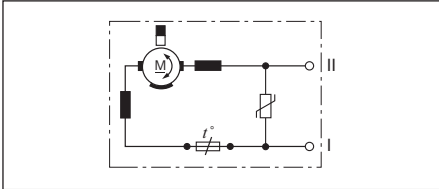
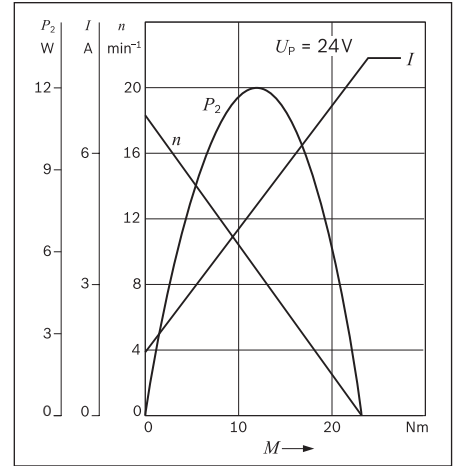

Clockwise: (+) to II, (-) to I  
 Anti-clockwise: (+) to I, (-) to II  
 ¹) On request

# AHC

## with Hall sensor

## 24 V 5 W

Part number	<b>0 390 203 312</b>
mirror-image	<b>0 390 203 313</b>
Nominal voltage	$U_N$ 24 V
Nominal power	$P_N$ 5 W
Nominal current	$I_N$ < 2,3 A
Maximum current	$I_{max}$ 7 A
Nominal speed	$n_N$ 16 min <sup>-1</sup>
Nominal torque	$M_N$ 3 Nm
Breakaway torque	$M_A$ > 22 Nm
Reduction	i 217 : 1
Direction of rotation	L/R
Type of duty	S 2 - 5 min
Degree of protection	IP 50
Weight	approx. 0,50 kg

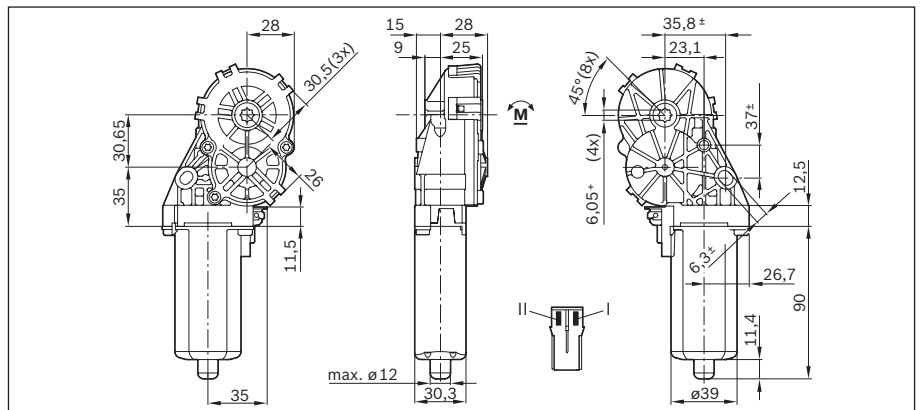
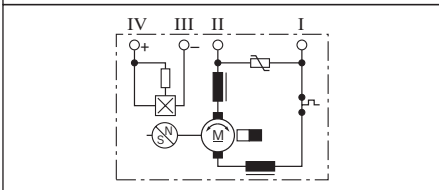
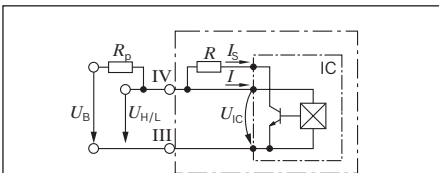
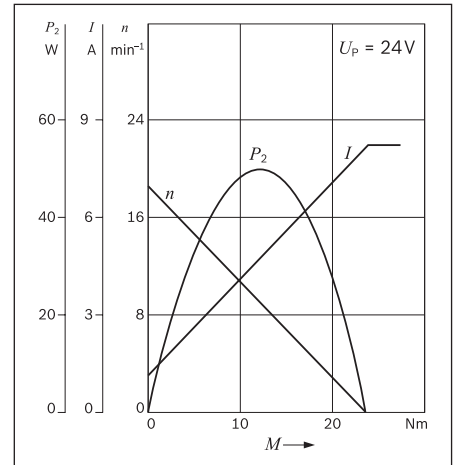

Clockwise: (+) to II, (-) to I  
 Anti-clockwise: (+) to I, (-) to II  
 ¹) On request

# AHC

## 24 V 29 W

Part number	<b>0 390 203 314</b>
mirror-image	<b>0 390 203 315</b>
Nominal voltage	$U_N$ 24 V
Nominal power	$P_N$ 29 W
Nominal current	$I_N$ < 5 A
Maximum current	$I_{max}$ 15 A
Nominal speed	$n_N$ 700 min <sup>-1</sup>
Nominal torque	$M_N$ 0,4 Nm
Breakaway torque	$M_A$ > 1,85 Nm
Direction of rotation	R/L
Type of duty	S 2
Degree of protection	IP 50
Weight	approx. 0,40 kg

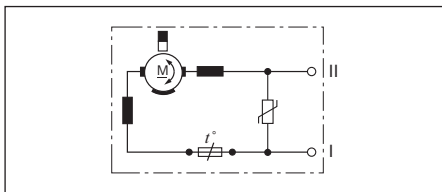
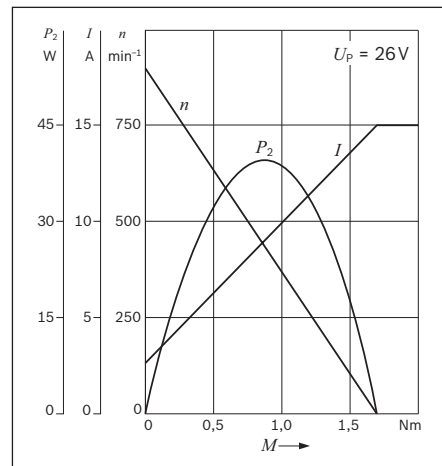

Clockwise: (+) to II, (-) to I  
 Anti-clockwise: (+) to I, (-) to II

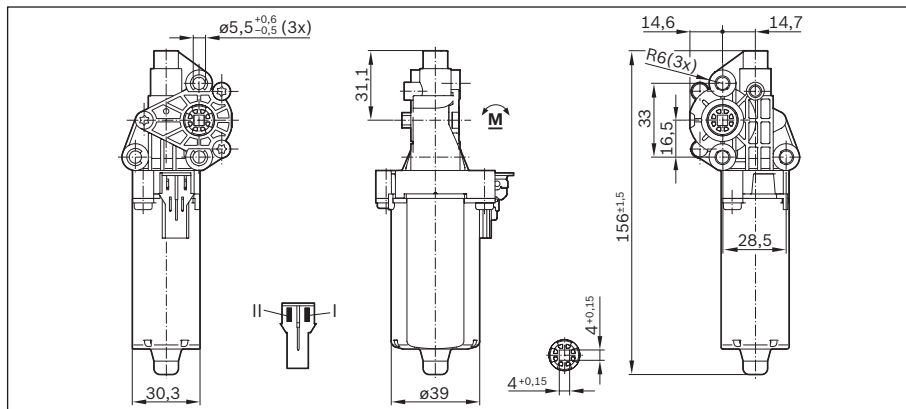

# AHC

with Hall sensor

## 24 V 29 W

Part number	<b>0 390 203 316</b>
mirror-image	<b>0 390 203 317</b>
Nominal voltage	$U_N$ 24 V
Nominal power	$P_N$ 29 W
Nominal current	$I_N$ < 5 A
Maximum current	$I_{max}$ 15 A
Nominal speed	$n_N$ 700 min <sup>-1</sup>
Nominal torque	$M_N$ 0,4 Nm
Breakaway torque	$M_A$ > 1,85 Nm
Direction of rotation	R/L
Type of duty	S 2
Degree of protection	IP 50
Weight	approx. 0,40 kg

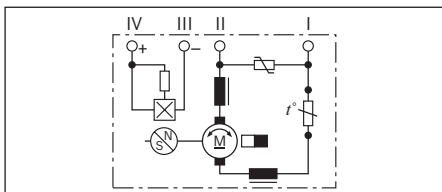
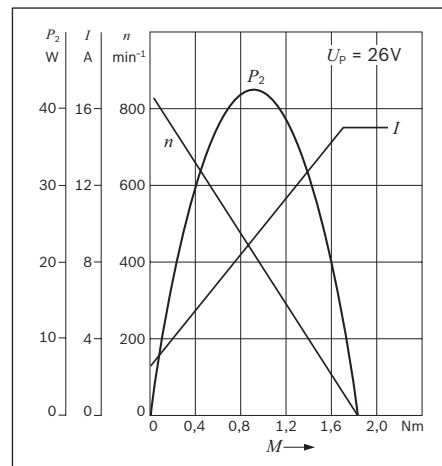

Clockwise: (+) to II, (-) to I  
 Anti-clockwise: (+) to I, (-) to II

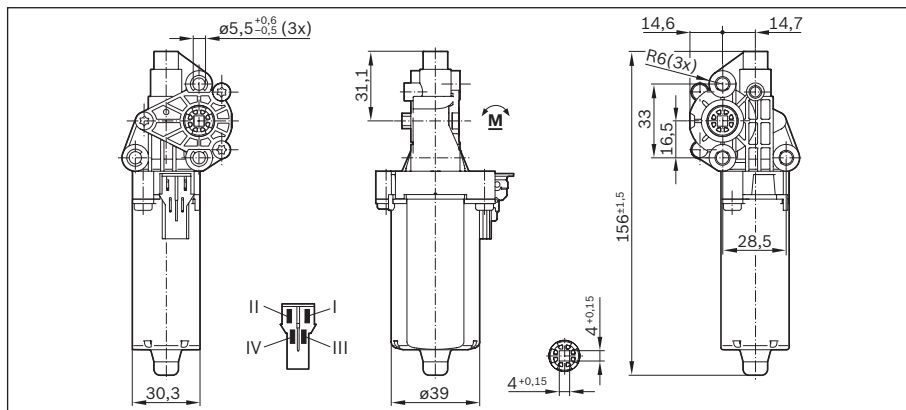



# NSA-MS

## 12 V

Part number	<b>0 390 204 027</b>
Nominal voltage	$U_N$ 12 V
Nominal current	$I_N$ 8 A
Maximum current	$I_{max}$ 24 A
Maximum force	$F_{max}$ 4100 N
Adjustment speed	$v_N$ 8 mm/s
Type of duty	S 3
Degree of protection	IP 50
Weight	approx. 0,52 kg

Clockwise: (+) to 1, (-) to 3  
 Counterclockwise: (+) to 3, (-) to 1

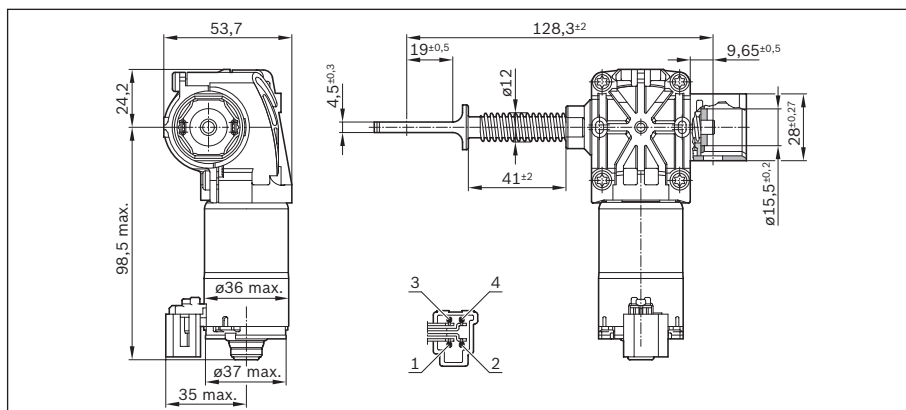
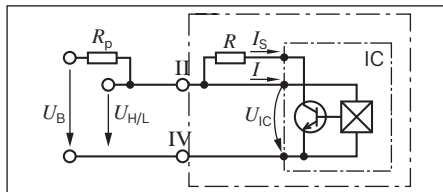
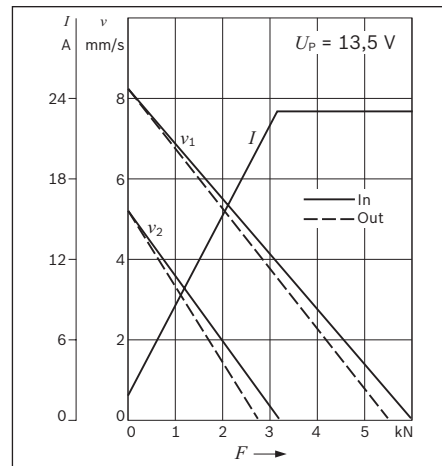

## FPG 2

### 12 V 21 W

Part number	<b>0 130 822 488</b>
mirror-image	<b>0 130 822 489</b>
Nominal voltage	$U_N$ 12 V
Nominal power	$P_N$ 21 W
Nominal current	$I_N$ 11 A
Maximum current	$I_{max}$ 34 A
Nominal speed	$n_N$ 74 min <sup>-1</sup>
Nominal torque	$M_N$ 2,7 Nm
Breakaway torque	$M_A$ 13,5 Nm
Reduction	i 73 : 1
Direction of rotation	L/R
Type of duty	S 2
Degree of protection	IP 53
Weight	approx. 0,59 kg

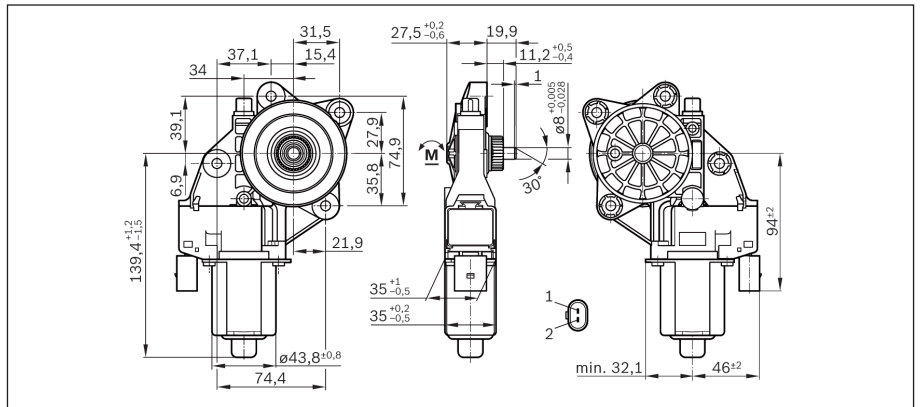
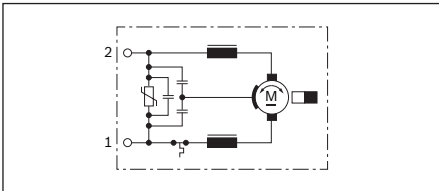
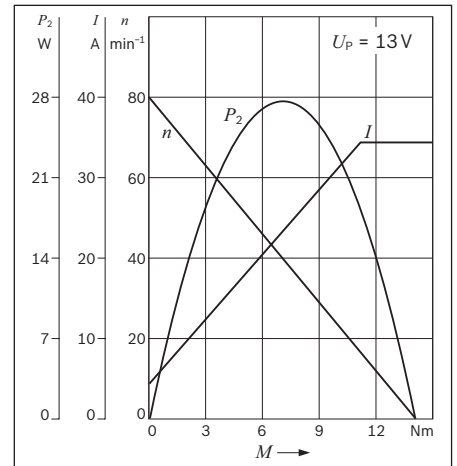

## FPG 2

### 24 V 21 W

Part number	<b>0 130 822 490</b>
mirror-image	<b>0 130 822 491</b>
Nominal voltage	$U_N$ 24 V
Nominal power	$P_N$ 21 W
Nominal current	$I_N$ 11 A
Maximum current	$I_{max}$ 34 A
Nominal speed	$n_N$ 74 min <sup>-1</sup>
Nominal torque	$M_N$ 2,7 Nm
Breakaway torque	$M_A$ 13,5 Nm
Reduction	i 73 : 1
Direction of rotation	L/R
Type of duty	S 2
Degree of protection	IP 53
Weight	approx. 0,59 kg

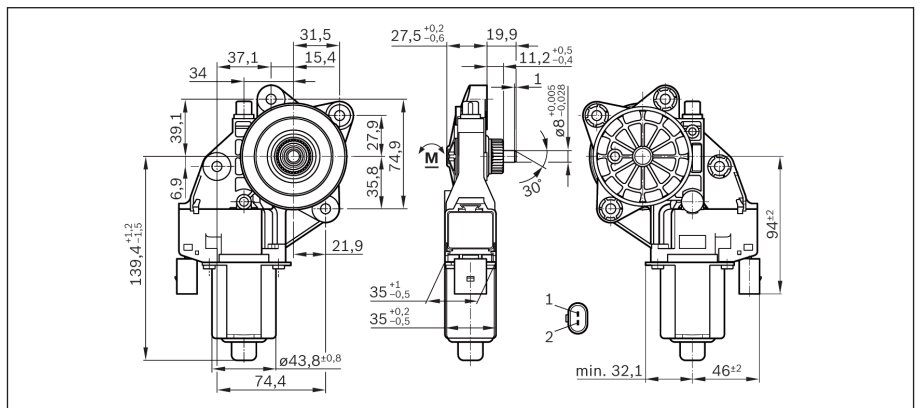
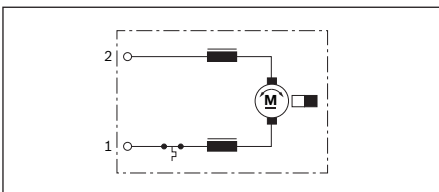
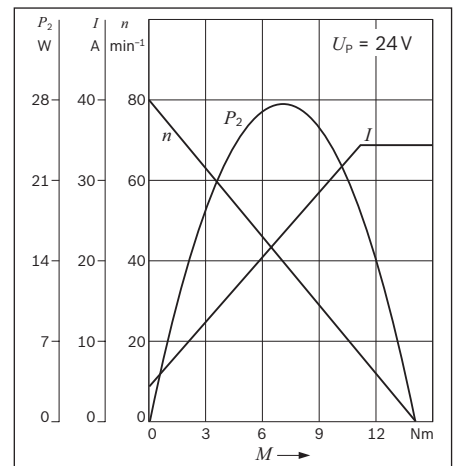



## FPG 2 with Hall sensor

### 12 V 21 W

Part number	<b>0 130 822 492</b>
mirror-image	<b>0 130 822 493</b>
Nominal voltage	$U_N$ 12 V
Nominal power	$P_N$ 21 W
Nominal current	$I_N$ 11 A
Maximum current	$I_{max}$ 34 A
Nominal speed	$n_N$ 74 min <sup>-1</sup>
Nominal torque	$M_N$ 2,7 Nm
Breakaway torque	$M_A$ 13,5 Nm
Reduction	i 73 : 1
Direction of rotation	L/R
Type of duty	S 2
Degree of protection	IP 53
Weight	approx. 0,59 kg

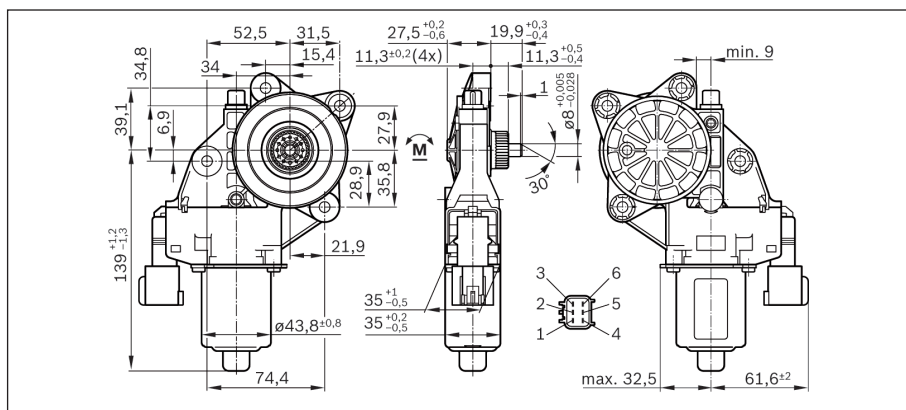
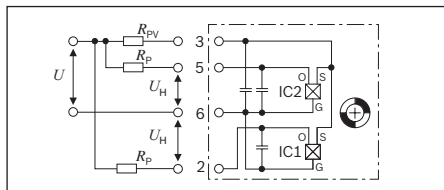
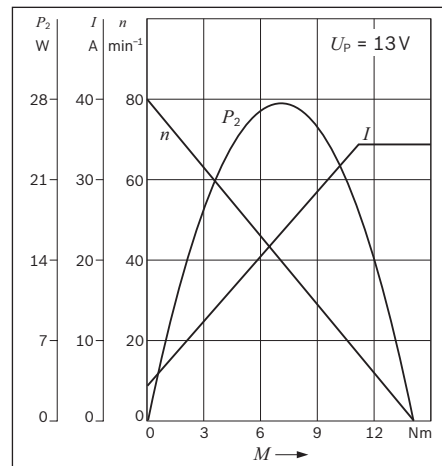

## FPG 2 with Hall sensor

### 24 V 21 W

Part number	<b>0 130 822 494</b>
mirror-image	<b>0 130 822 495</b>
Nominal voltage	$U_N$ 24 V
Nominal power	$P_N$ 21 W
Nominal current	$I_N$ 11 A
Maximum current	$I_{max}$ 34 A
Nominal speed	$n_N$ 74 min <sup>-1</sup>
Nominal torque	$M_N$ 2,7 Nm
Breakaway torque	$M_A$ 13,5 Nm
Reduction	i 73 : 1
Direction of rotation	L/R
Type of duty	S 2
Degree of protection	IP 53
Weight	approx. 0,59 kg

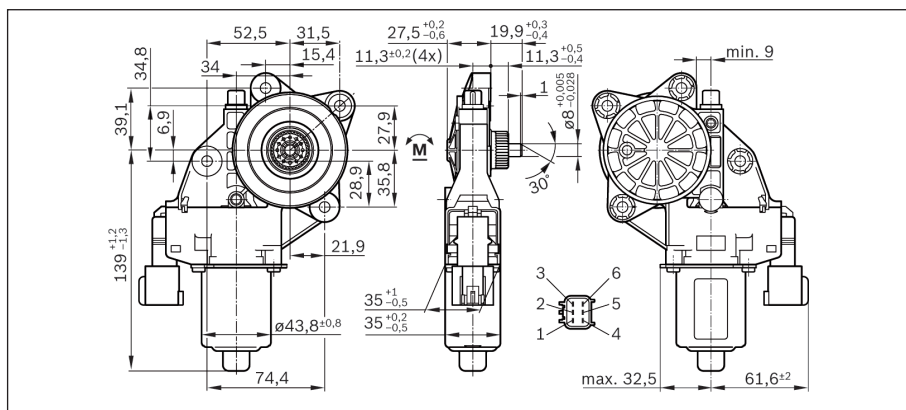
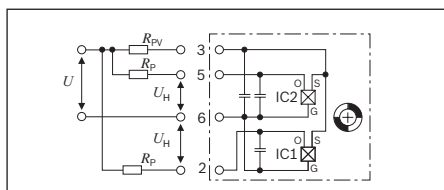
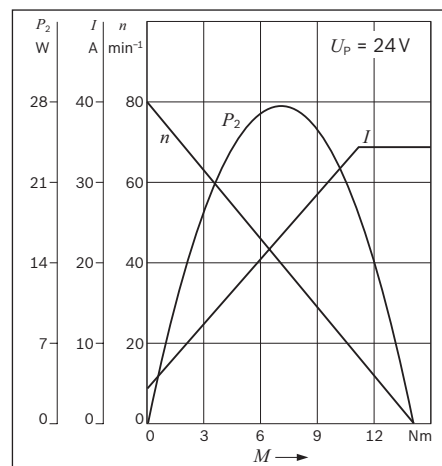

# CHP

## 24 V 57 W

Part number	<b>0 390 257 693</b>
Nominal voltage	$U_N$ 24 V
Nominal power	$P_N$ 57 W
Nominal current	$I_N$ 3,5 A
Maximum current	$I_{max}$ 16 A
Nominal speed	$n_N$ 90 min <sup>-1</sup>
Nominal torque	$M_N$ 4,5 Nm
Breakaway torque	$M_A$ 16 Nm
Reduction	i 52 : 2
Direction of rotation	L/R
Type of duty	S 1
Degree of protection	IP 23
Weight	approx. 1,10 kg

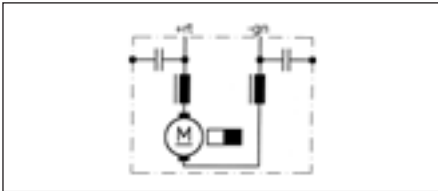
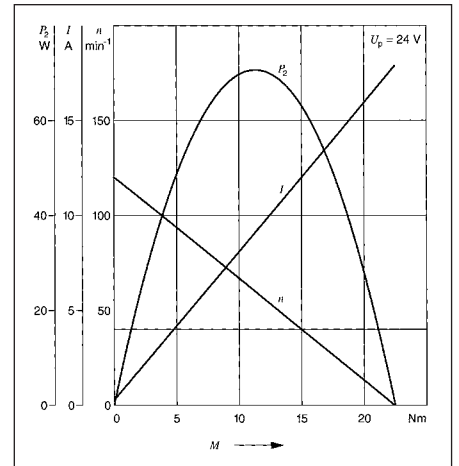

Clockwise: (-) at gn terminal (green)  
 Anti-clockwise: (+) to red, (-) to green.

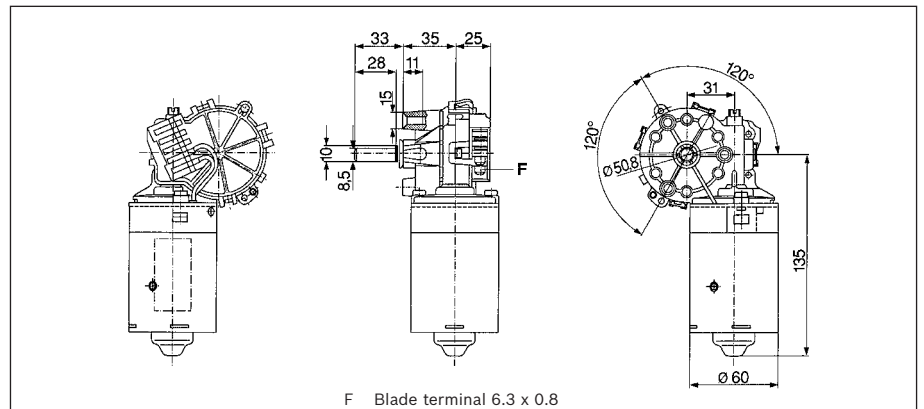

# CHP

## 12V 14 W

Part number	<b>F 006 B20 092</b>
Nominal voltage	$U_N$ 12 V
Nominal power	$P_N$ 14 W
Nominal current	$I_N$ 6,1 A
Maximum current	$I_{max}$ 27 A
Nominal speed	$n_N$ 49 min <sup>-1</sup>
Nominal torque	$M_N$ 2,7 Nm
Breakaway torque	$M_A$ 27 Nm
Direction of rotation	L/R
Type of duty	S1
Degree of protection	IP 23
Weight	approx. 1,10 kg

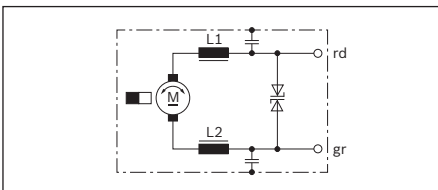
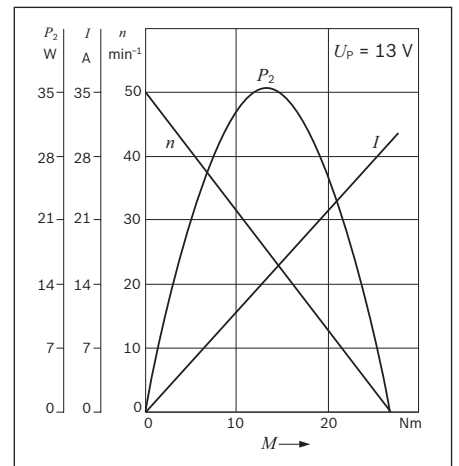

Clockwise: (+) to red, (-) to green  
 Anti-clockwise: (+) to green, (-) to red

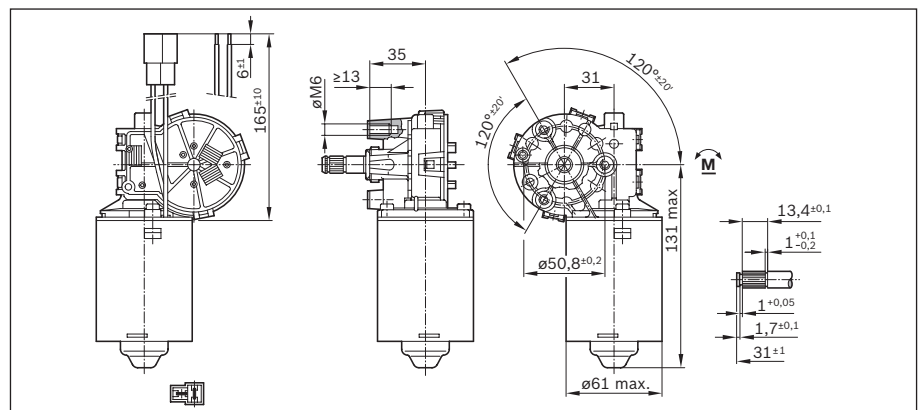

# CHP

## 12 V 42 W

Part number	<b>F 006 B20 093</b>
Nominal voltage	$U_N$ 12 V
Nominal power	$P_N$ 42 W
Nominal current	$I_N$ 9,4 A
Maximum current	$I_{max}$ 45 A
Nominal speed	$n_N$ 135 min <sup>-1</sup>
Nominal torque	$M_N$ 3 Nm
Breakaway torque	$M_A$ 17,5 Nm
Reduction	i 52 : 2
Direction of rotation	L/R
Type of duty	S 1
Degree of protection	IP 23
Weight	approx. 1,10 kg
Similar part number	0 390 251 684

Clockwise: (+) to green, (-) to brown  
 Anti-clockwise: (+) to brown, (-) to green  
 On request

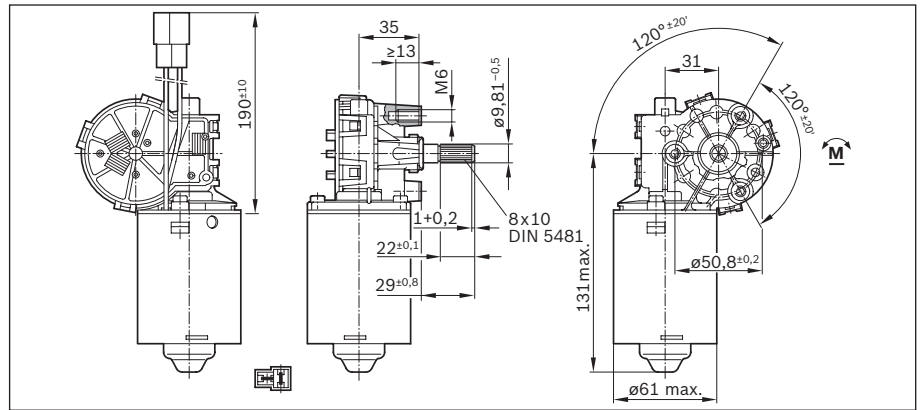
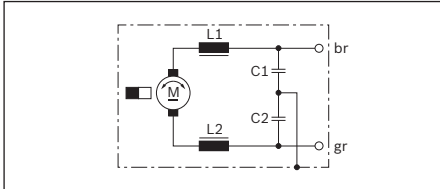
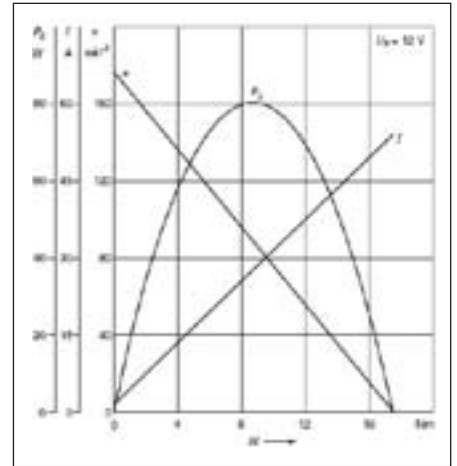

# CHP

## 24V 13W

Part number	<b>F 006 B20 095</b>
Nominal voltage	$U_N$ 24 V
Nominal power	$P_N$ 13 W
Nominal current	$I_N$ 1,9 A
Maximum current	$I_{max}$ 8 A
Nominal speed	$n_N$ 46 min <sup>-1</sup>
Nominal torque	$M_N$ 2,5 Nm
Breakaway torque	$M_A$ 25 Nm
Reduction	i 55 : 1
Direction of rotation	L/R
Type of duty	S 1
Degree of protection	IP 23
Weight	approx. 1,20 kg
Similar part number	0 390 257 699

Clockwise: (+) to green, (-) to brown  
 Anti-clockwise: (+) to brown, (-) to green

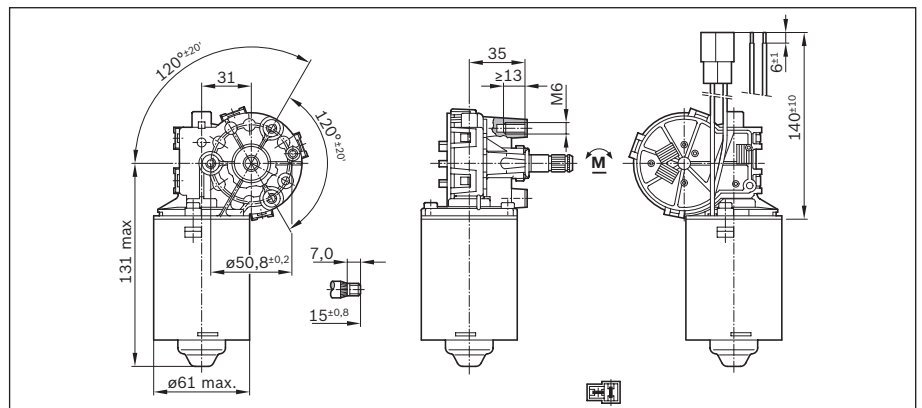
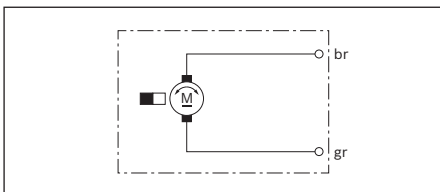
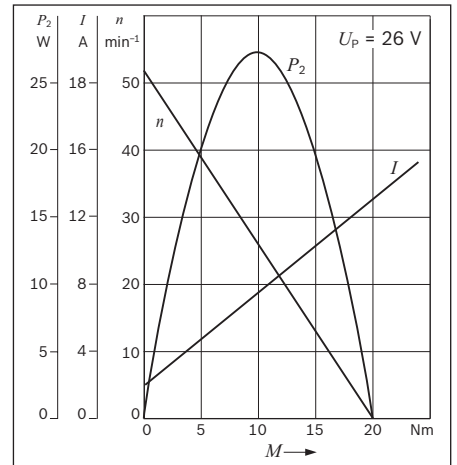

# CHP

## 24V 12W

Part number	<b>F 006 B20 096</b>
Nominal voltage	$U_N$ 24 V
Nominal power	$P_N$ 12 W
Nominal current	$I_N$ 2,7 A
Maximum current	$I_{max}$ 11 A
Nominal speed	$n_N$ 40 min <sup>-1</sup>
Nominal torque	$M_N$ 2,9 Nm
Breakaway torque	$M_A$ 29 Nm
Reduction	i 55 : 1
Direction of rotation	L/R
Type of duty	S 1
Degree of protection	IP 23
Weight	approx. 1,20 kg

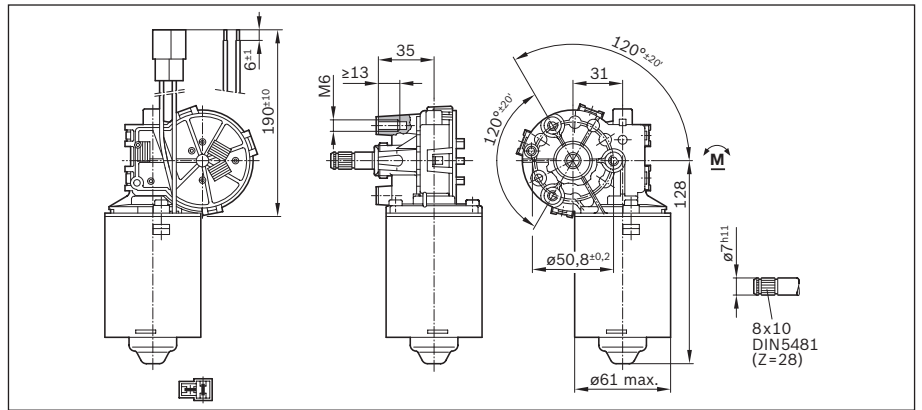
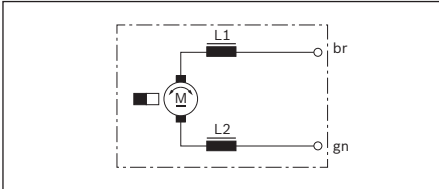
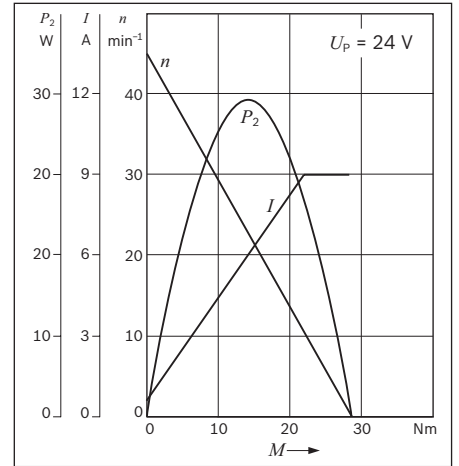

# CHP

## 24 V 16.6 W

Part number	<b>F 006 B20 097</b>
Nominal voltage	$U_N$ 24 V
Nominal power	$P_N$ 16,6 W
Nominal current	$I_N$ 5,3 A
Maximum current	$I_{max}$ 21 A
Nominal speed	$n_N$ 66 min <sup>-1</sup>
Nominal torque	$M_N$ 2,4 Nm
Breakaway torque	$M_A$ 24 Nm
Reduction	i 69 : 1
Direction of rotation	L/R
Type of duty	S 1
Degree of protection	IP 23
Weight	approx. 1,20 kg
Similar part number	0 390 257 685

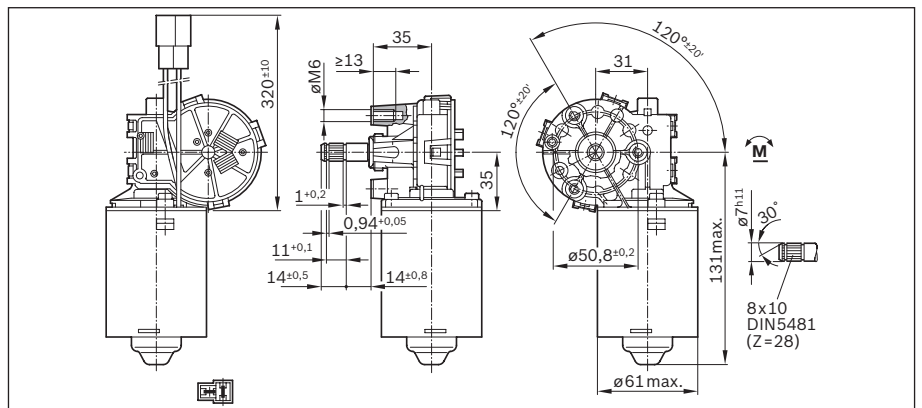
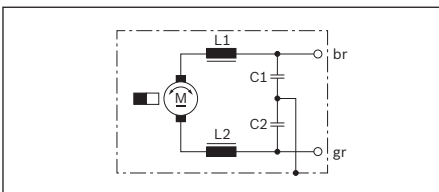
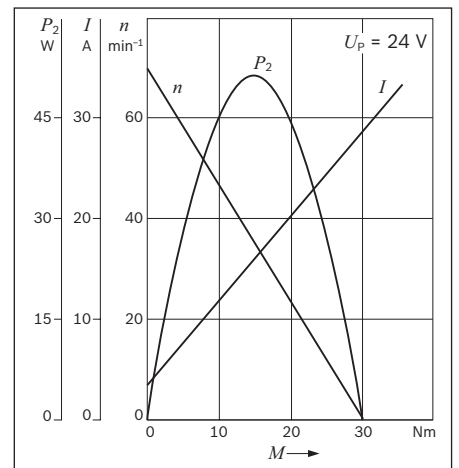

# CHP

## 24V 26W

Part number	<b>F 006 B20 098</b>
Nominal voltage	$U_N$ 24 V
Nominal power	$P_N$ 22 W
Nominal current	$I_N$ 4 A
Maximum current	$I_{max}$ 17 A
Nominal torque	$M_N$ 5 Nm
Breakaway torque	$M_A$ 27 Nm
Reduction	i 55 : 1
Direction of rotation	L/R
Type of duty	S 1
Degree of protection	IP 23
Weight	approx. 1,00 kg
Similar part number	0 390 257 690

Clockwise: (+) to green, (-) to brown  
 Anti-clockwise: (+) to brown, (-) to green

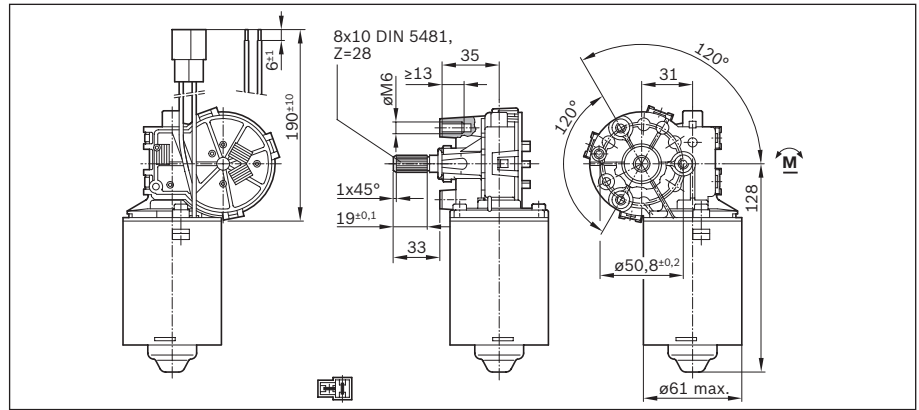
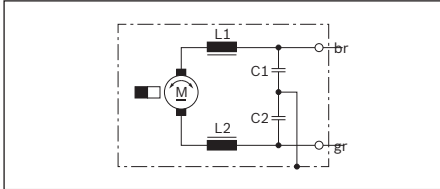
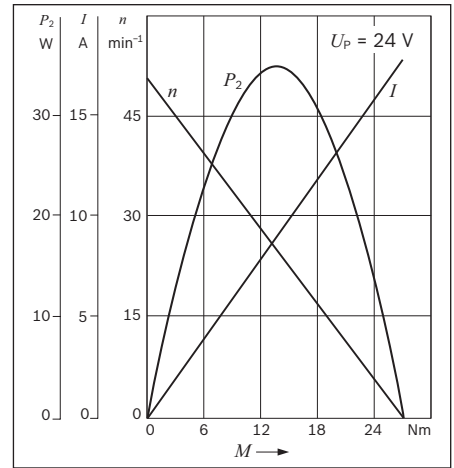

# CHP

## 24 V 18 W

Part number	<b>F 006 B20 099</b>
Nominal voltage	$U_N$ 24 V
Nominal power	$P_N$ 18 W
Nominal current	$I_N$ 4 A
Maximum current	$I_{max}$ 15 A
Nominal speed	$n_N$ 122 $\text{min}^{-1}$
Nominal torque	$M_N$ 1,4 Nm
Breakaway torque	$M_A$ 14 Nm
Reduction	i 52 : 2
Direction of rotation	L/R
Type of duty	S 1
Degree of protection	IP 23
Weight	approx. 1,10 kg
Similar part number	0 390 257 694

Clockwise: (+) to green, (-) to brown  
 Anti-clockwise: (+) to brown, (-) to green

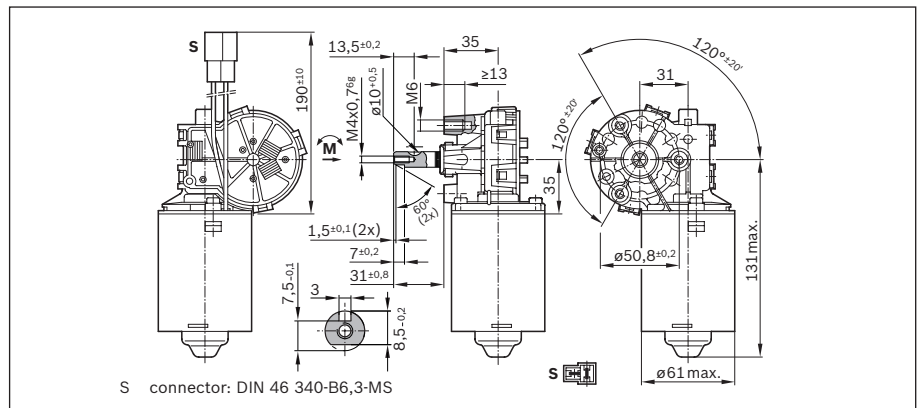
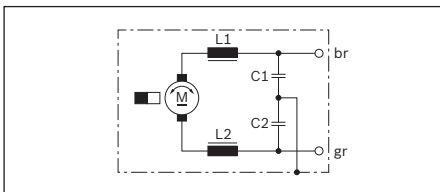
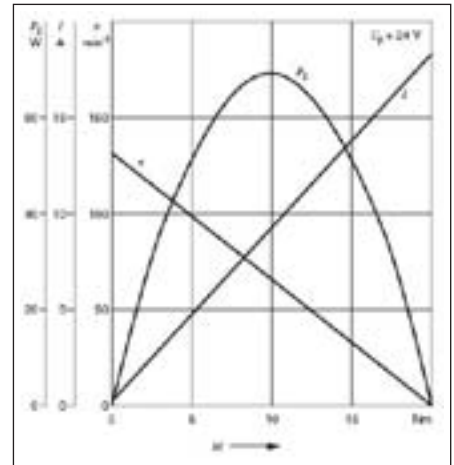



# CHP

## 24V 29W

Part number	<b>F 006 B20 100</b>
Nominal voltage	$U_N$ 24 V
Nominal power	$P_N$ 29 W
Nominal current	$I_N$ 3,3 A
Maximum current	$I_{max}$ 14 A
Nominal speed	$n_N$ 94 min <sup>-1</sup>
Nominal torque	$M_N$ 3 Nm
Breakaway torque	$M_A$ 20 Nm
Reduction	i 52 : 2
Direction of rotation	L/R
Type of duty	S 1
Degree of protection	IP 23
Weight	approx. 1,00 kg
Similar part number	0 390 257 687

Clockwise: (+) to green, (-) to brown  
 Anti-clockwise: (+) to brown, (-) to green

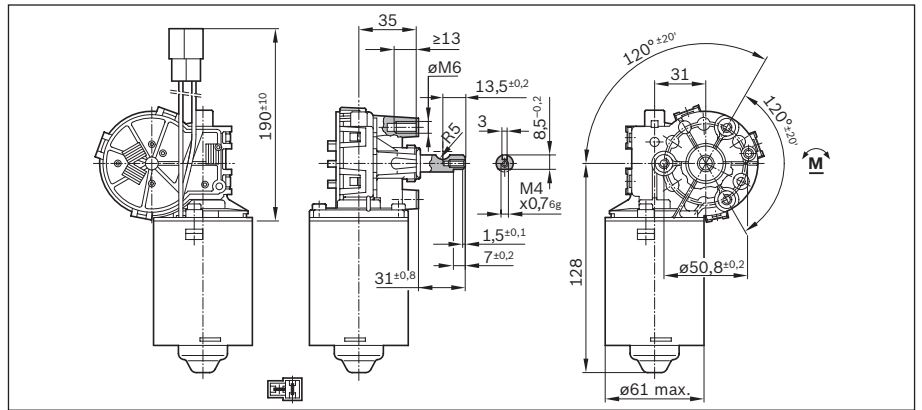
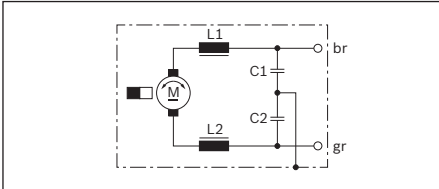
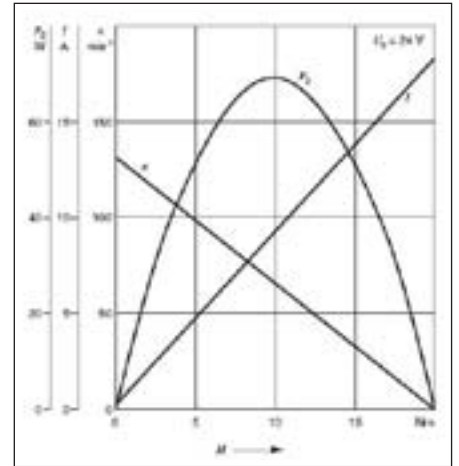

# CHP

## 24 V 19 W

Part number	<b>F 006 B20 101</b>
Nominal voltage	$U_N$ 24 V
Nominal power	$P_N$ 19 W
Nominal current	$I_N$ 3,3 A
Maximum current	$I_{max}$ 14,5 A
Nominal speed	$n_N$ 113 min <sup>-1</sup>
Nominal torque	$M_N$ 1,6 Nm
Breakaway torque	$M_A$ 16 Nm
Reduction	i 52 : 2
Direction of rotation	L/R
Type of duty	S 1
Degree of protection	IP 23
Weight	approx. 1,10 kg
Similar part number	0 390 257 693

Clockwise: (+) to green, (-) to brown  
 Anti-clockwise: (+) to brown, (-) to green

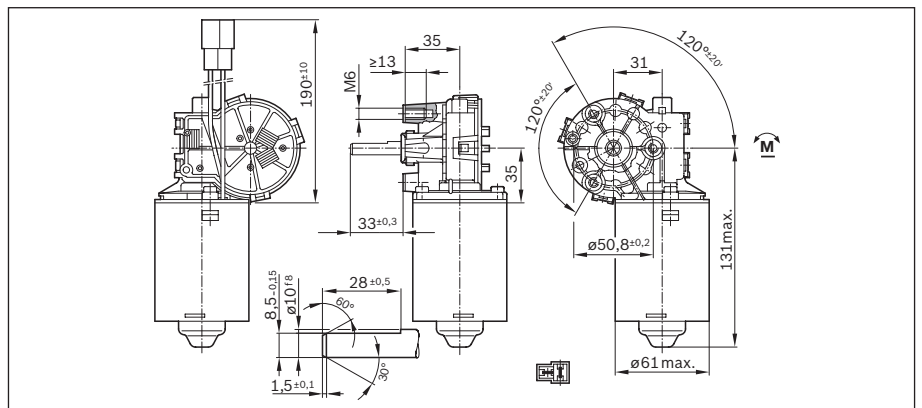
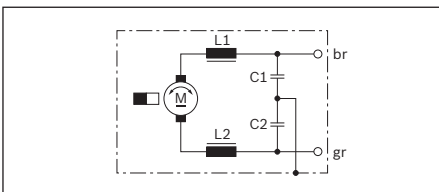
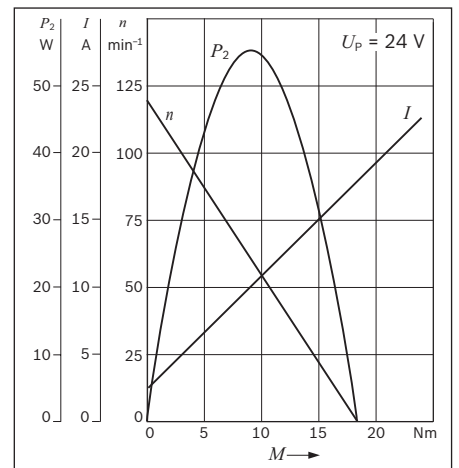

# CHP

## 24V 24W

Part number	<b>F 006 B20 102</b>
Nominal voltage	$U_N$ 24 V
Nominal power	$P_N$ 24 W
Nominal current	$I_N$ 4,5 A
Maximum current	$I_{max}$ 18 A
Nominal speed	$n_N$ 174 min <sup>-1</sup>
Nominal torque	$M_N$ 1,3 Nm
Breakaway torque	$M_A$ 13 Nm
Reduction	i 52 : 2
Direction of rotation	L/R
Type of duty	S 1
Degree of protection	IP 23
Weight	approx. 1,10 kg
Similar part number	0 390 257 691

Clockwise: (+) to green, (-) to brown  
 Anti-clockwise: (+) to brown, (-) to green

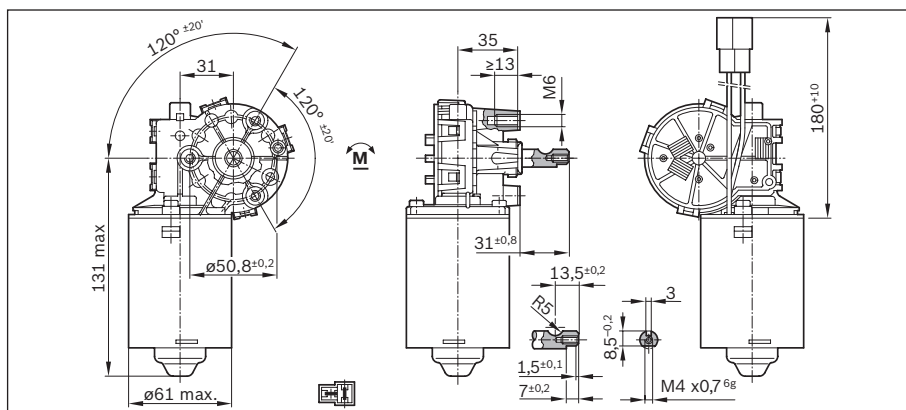
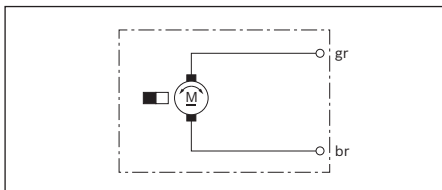
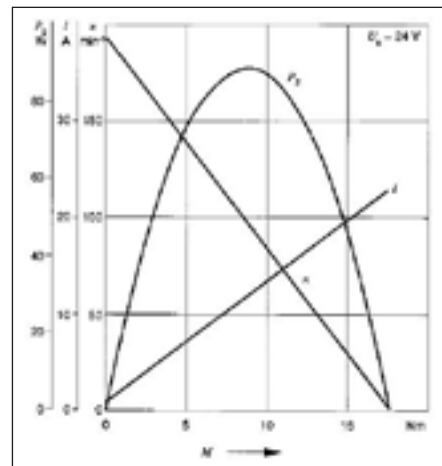

# CHP

## 24V 16W

Part number	<b>F 006 B20 103</b>
Nominal voltage	$U_N$ 24 V
Nominal power	$P_N$ 36 W
Nominal current	$I_N$ 5,8 A
Maximum current	$I_{max}$ 31 A
Nominal speed	$n_N$ 177 min <sup>-1</sup>
Nominal torque	$M_N$ 1,9 Nm
Breakaway torque	$M_A$ 19 Nm
Reduction	i 52 : 2
Direction of rotation	L/R
Type of duty	S 1
Degree of protection	IP 23
Weight	approx. 1,10 kg
Similar part number	0 390 257 688

Clockwise: (+) to green, (-) to brown  
 Anti-clockwise: (+) to brown, (-) to green

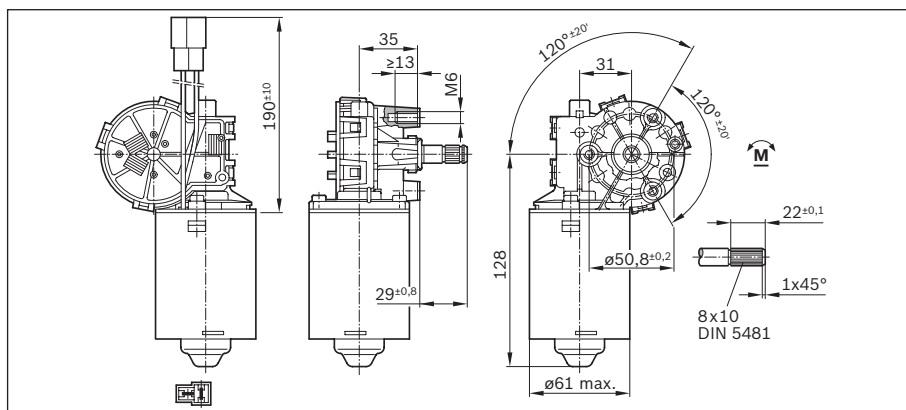
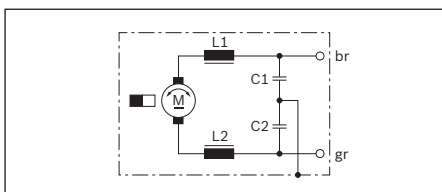
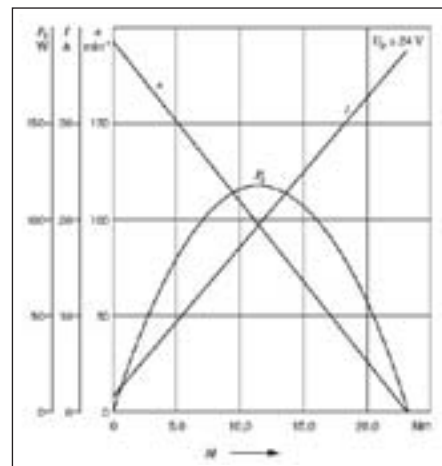

# CEP

## 24 V 16 W

Part number	<b>F 006 B20 106</b>
Nominal voltage	$U_N$ 24 V
Nominal power	$P_N$ 16 W
Nominal current	$I_N$ 4,9 A
Maximum current	$I_{max}$ 14,5 A
Nominal speed	$n_N$ 47 min <sup>-1</sup>
Nominal torque	$M_N$ 3,3 Nm
Breakaway torque	$M_A$ 33 Nm
Reduction	i 79 : 1
Direction of rotation	L/R
Type of duty	S 1
Degree of protection	IP 23
Weight	approx. 1,30 kg

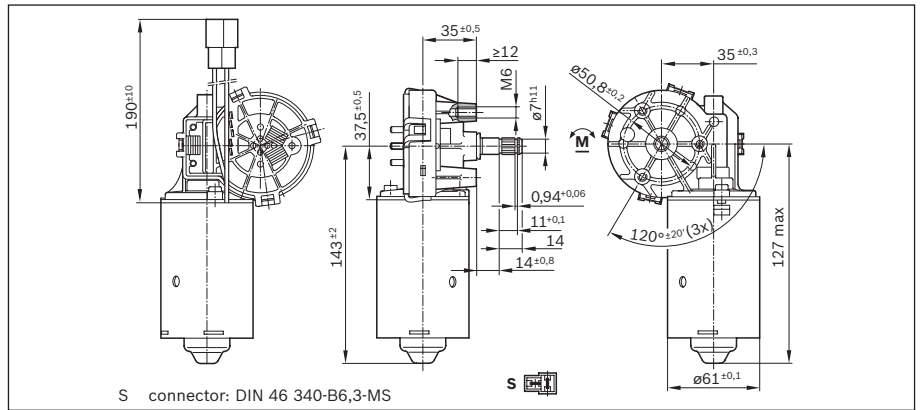
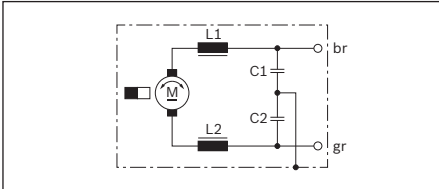
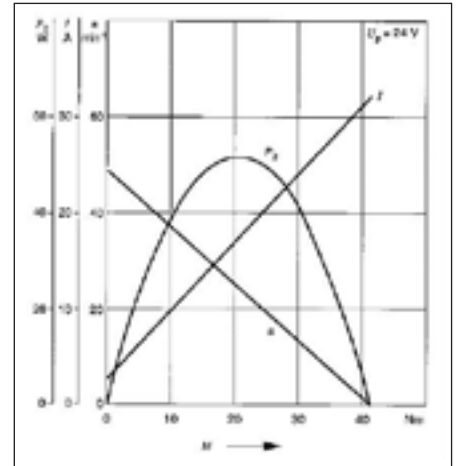

# WSM3-IK

## 24 V 35 W

Part number	<b>F 006 B20 412</b>
mirror-image	<b>F 006 B20 413</b>
Nominal voltage	$U_N$ 24 V
Nominal power	$P_N$ 35 W
Nominal current	$I_N$ 6,5 A
Maximum current	$I_{max}$ 12,5 A
Nominal speed	$n_N$ 55 min <sup>-1</sup>
Nominal torque	$M_N$ 6 Nm
Breakaway torque	$M_A$ 30 Nm
Reduction	i 1 : 88
Direction of rotation	R/L
Type of duty	S1
Degree of protection	IP30
Weight	approx. 0,98 kg

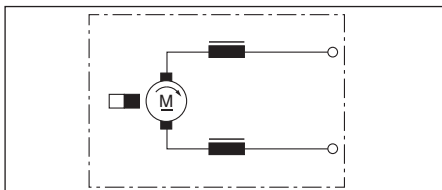
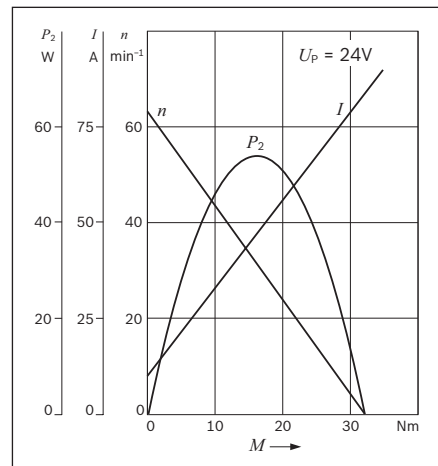

Clockwise: B on (+), A on (-)  
 Counterclockwise: A on (+), B on (-)

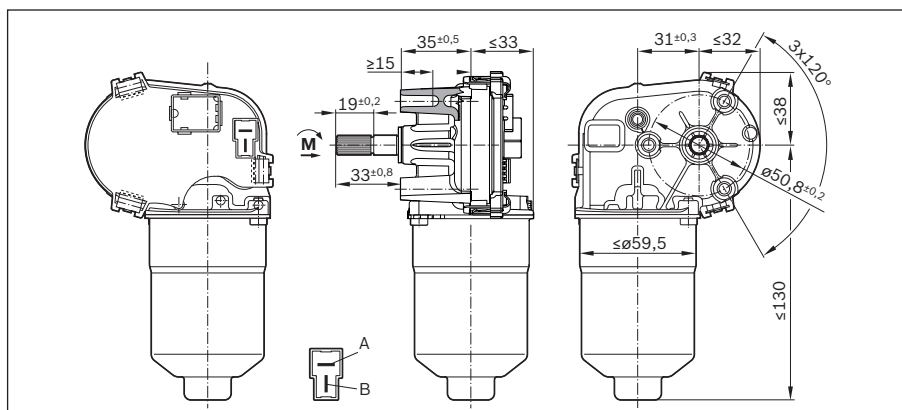
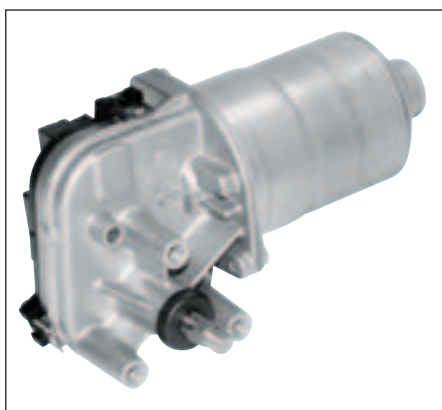

# WSM3-IK

with Hall sensor

## 24 V 35 W

Part number	<b>F 006 B20 410</b>
mirror-image	<b>F 006 B20 411</b>
Nominal voltage	$U_N$ 24 V
Nominal power	$P_N$ 35 W
Nominal current	$I_N$ 6,5 A
Maximum current	$I_{max}$ 12,5 A
Nominal speed	$n_N$ 55 min <sup>-1</sup>
Nominal torque	$M_N$ 6 Nm
Breakaway torque	$M_A$ 30 Nm
Reduction	i 1 : 88
Direction of rotation	R/L
Type of duty	S1
Degree of protection	IP30
Weight	approx. 0,98 kg

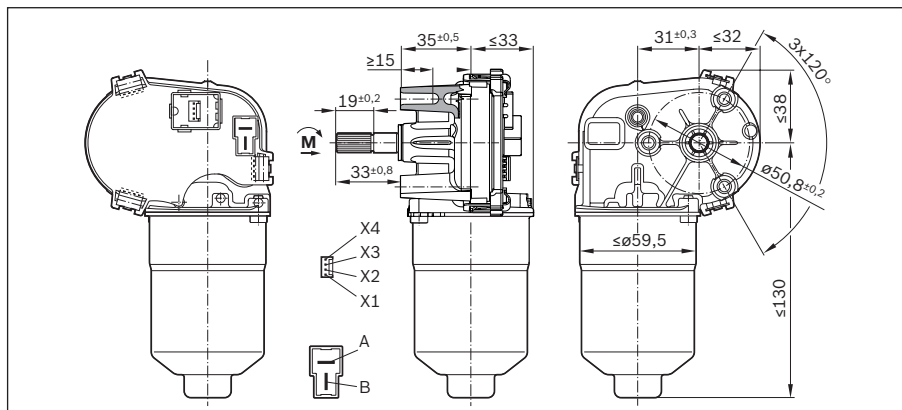
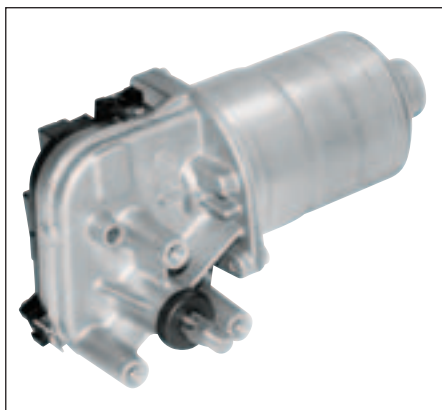
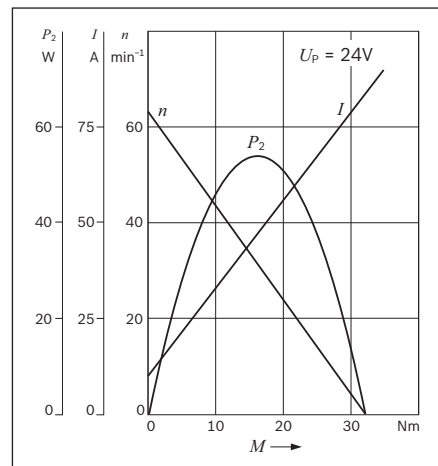

Clockwise: B on (+), A on (-)  
 Counterclockwise: A on (+), B on (-)

# EFP

## 12 V

Part number	<b>0 986 337 400</b>
Nominal voltage	$U_N$ 12 V
Nominal power	$P_N$ 8/13,6 W
Nominal current	$I_N$ 2,4/4 A
Maximum current	$I_{max}$ 21/27 A
Nominal speed	$n_N$ 32/48 min <sup>-1</sup>
Nominal torque	$M_N$ 2,5/2,5 Nm
Breakaway torque	$M_A$ 45/35 Nm
Reduction	i 80 : 2
Direction of rotation	L
Type of duty	S1
Degree of protection	33
Weight	approx. 2,90 kg

Clockwise: 3 on (-), 1 on (+)  
 Anti-clockwise: 1 on (-), 3 on (+)

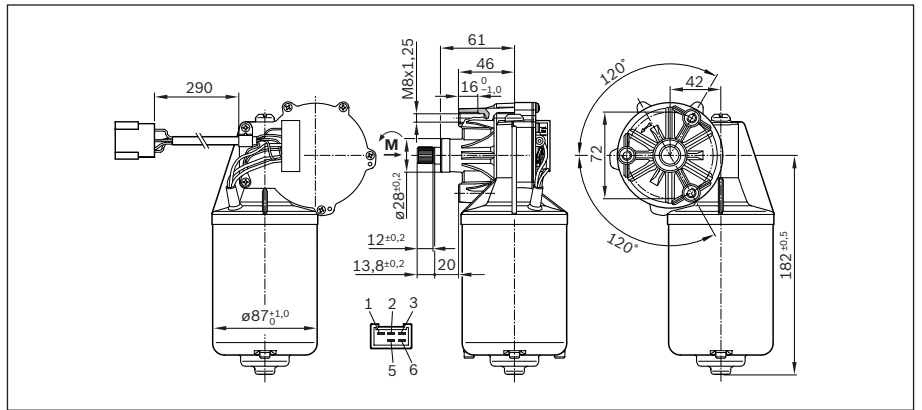
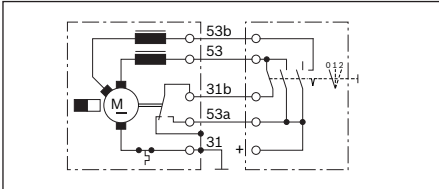
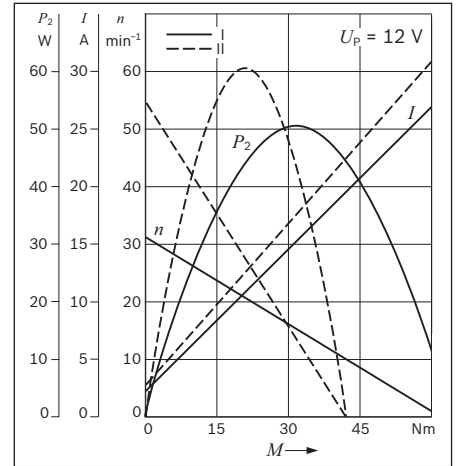

# EFP

## 24 V

Part number	<b>0 986 337 401</b>
Nominal voltage	$U_N$ 24 V
Nominal power	$P_N$ 10/15 W
Nominal current	$I_N$ 1,4/2,5 A
Maximum current	$I_{max}$ 13/20 A
Nominal speed	$n_N$ 35/51 min <sup>-1</sup>
Nominal torque	$M_N$ 3/3 Nm
Breakaway torque	$M_A$ 55/48 Nm
Reduction	i 80 : 2
Direction of rotation	L
Type of duty	S1
Degree of protection	IP33
Weight	approx. 2,90 kg

Clockwise: 3 on (-), 1 on (+)  
 Anti-clockwise: 1 on (-), 3 on (+)

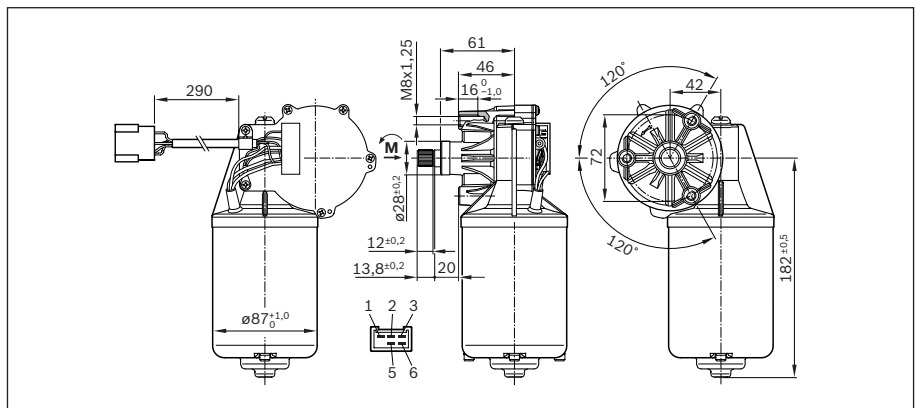
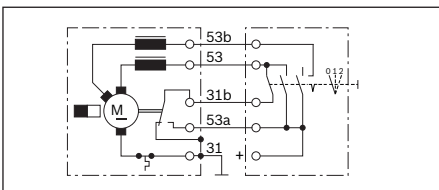
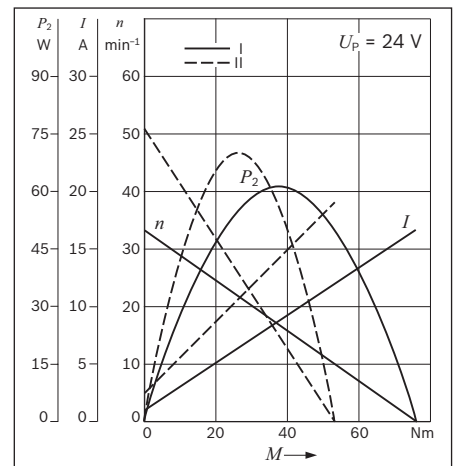



# EFP

## 24 V

Part number	<b>0 986 337 409</b>
Nominal voltage	$U_N$ 24 V
Nominal power	$P_N$ 56 W
Nominal current	$I_N$ 9 A
Maximum current	$I_{max}$ 36 A
Nominal speed	$n_N$ 60 min <sup>-1</sup>
Nominal torque	$M_N$ 10 Nm
Breakaway torque	$M_A$ 70 Nm
Reduction	i 80 : 2
Direction of rotation	L/R
Type of duty	S1
Degree of protection	IP33
Weight	approx. 2,90 kg

Clockwise: 5 on (-), 1 on (+)  
 Anti-clockwise: 1 on (-), 5 on (+)

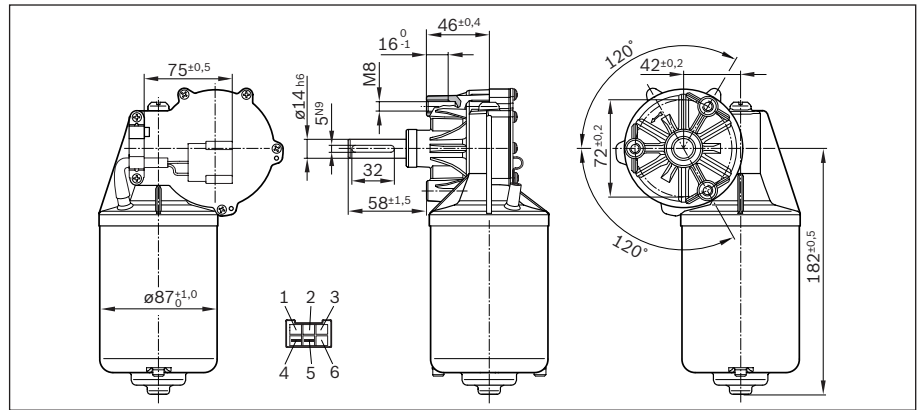
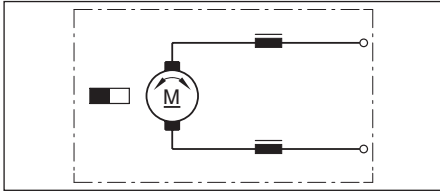
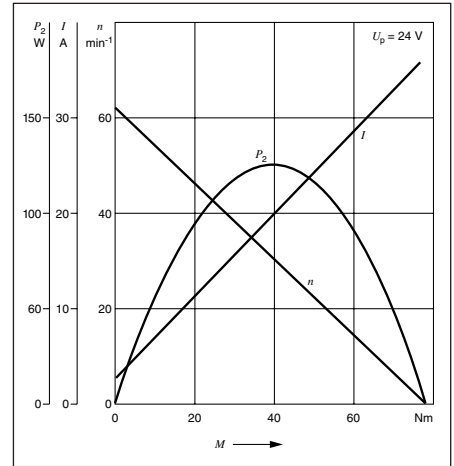

# EFP

## 24 V

Part number	<b>0 986 337 410</b>
Nominal voltage	$U_N$ 24 V
Nominal power	$P_N$ 67 W
Nominal current	$I_N$ 10 A
Maximum current	$I_{max}$ 42 A
Nominal speed	$n_N$ 75 min <sup>-1</sup>
Nominal torque	$M_N$ 10 Nm
Breakaway torque	$M_A$ 70 Nm
Reduction	i 80 : 2
Direction of rotation	L/R
Type of duty	S1
Degree of protection	IP33
Weight	approx. 2,90 kg

Clockwise: 5 on (-), 1 on (+)  
 Anti-clockwise: 1 on (-), 5 on (+)

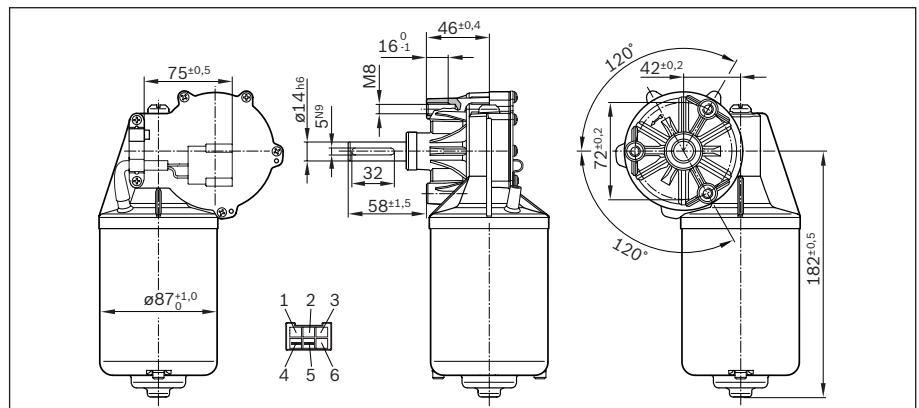
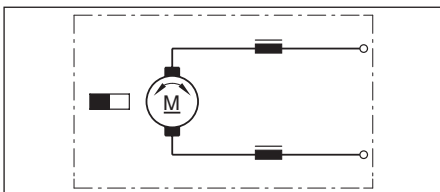
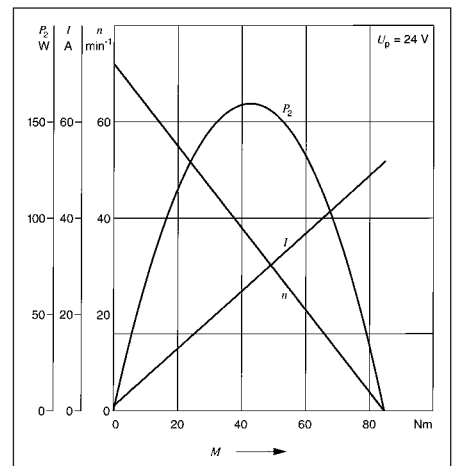



# EFP

## 24 V

Part number	<b>0 986 337 402</b>
Nominal voltage	$U_N$ 24 V
Nominal power	$P_N$ 18,43 W
Nominal current	$I_N$ 3 A
Maximum current	$I_{max}$ 17 A
Nominal speed	$n_N$ 44 min <sup>-1</sup>
Nominal torque	$M_N$ 4 Nm
Breakaway torque	$M_A$ 70 Nm
Reduction	i 65 : 1
Direction of rotation	L/R
Type of duty	S1
Degree of protection	IP33
Weight	approx. 2,90 kg

Clockwise: 3 on (-), 1 on (+)  
 Anti-clockwise: 1 on (-), 3 on (+)

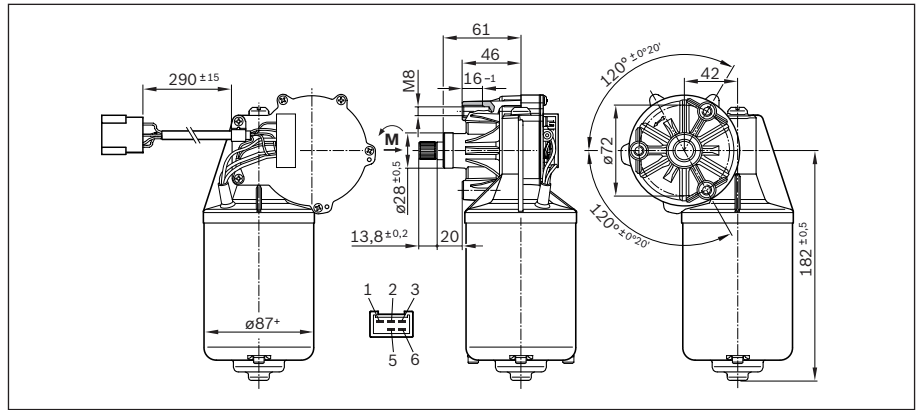
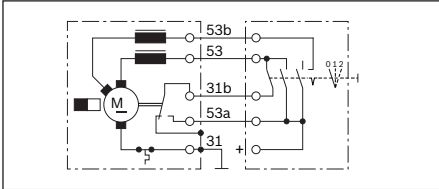
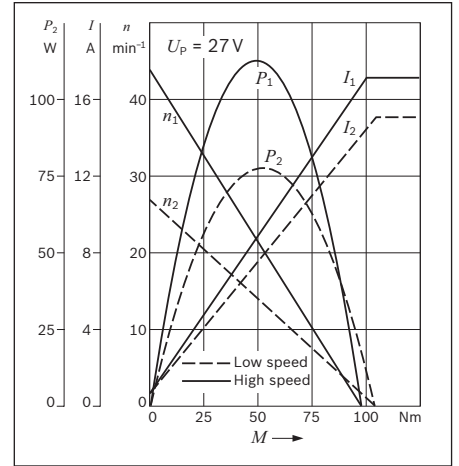



## WDD - Direct Drive

Control the speed, rotation, strokes and rotation angle with precision!

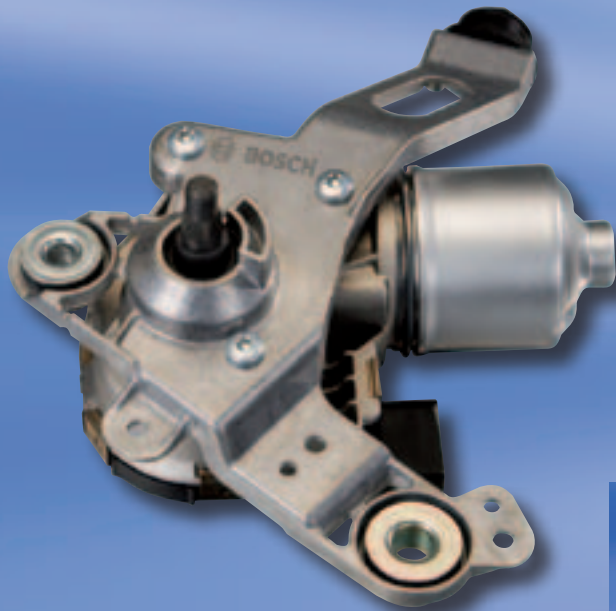

### Product features

- ▶ PWM driven DC motor
- ▶ Close loop control (PID) based on a contactless angular sensor
- ▶ Programmable angles, speeds and powerInterface: LIN 2.0
- ▶ Synchronization between two drives possible (Master-Slave)
- ▶ Powerful (torque  $\leq 34\text{Nm}$ )
- ▶ Fulfillment of new EMC requirements (Bluetooth, DVB-T, UMTS, etc.)

### Product description

The WDD is an electronically controlled motor with integrated ECU with the singularity of being customized - control the speed, rotation, strokes and rotation angle with precision!

Ideal for passenger cars and Off-Highway Industry it can drive i.e. a wiper directly but it can be used also for the Industrial customers. The integrated ECU needs customer specific software and this software adaptation can be done at Bosch.

### Operation

The drive receives requests via a LIN bus interface and is speed and position controlled. The controller thereby follows one of the set point position characteristic curves stored in the software of the integrated ECU.

The terminal voltage of the drive is adjusted in pulse-width modulated manner via an H-bridge-power-stage in a close loop control (PID) based on the integrated angular sensor.

### Notes on fixation bracket:

For the WDD fixation a special bracket is needed (for vibration and noise reduction). This bracket should be designed and sourced by the customer.

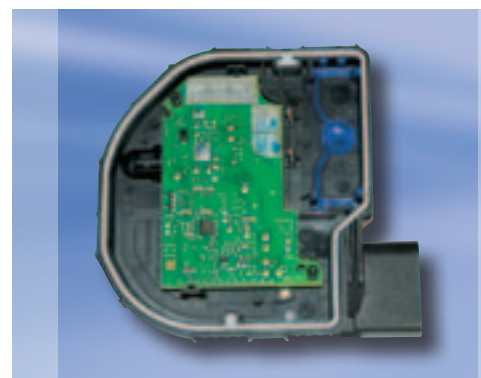

# WDD

with Hall sensor/  
illustration similar

## 12 V 22 W

Part number	<b>0 390 248 016</b>
Nominal voltage	$U_N$ 12 V
Nominal power	$P_N$ 22 W
Nominal current	$I_N$ 2,9 A
Maximum current	$I_{max}$ 19 A
Nominal speed	$n_N$ 53 min <sup>-1</sup>
Nominal torque	$M_N$ 4 Nm
Breakaway torque	$M_A$ 38 Nm
Reduction	i 1 : 76
Direction of rotation	L/R
Type of duty	S1
Degree of protection	IP6K7
Weight	approx. 1,33 kg

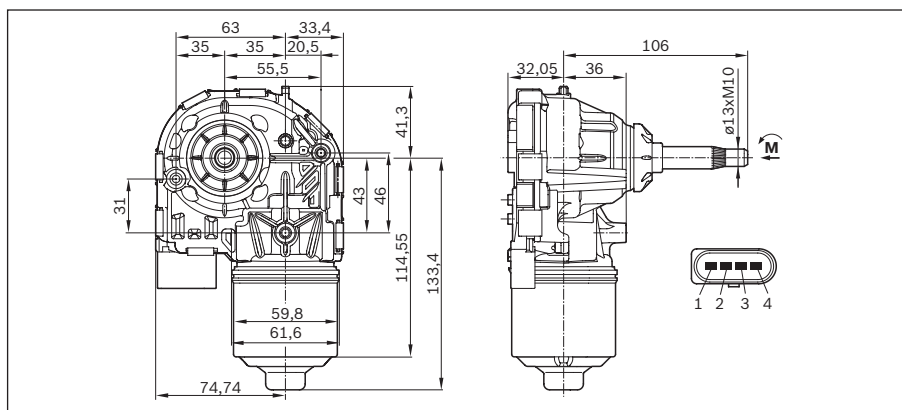
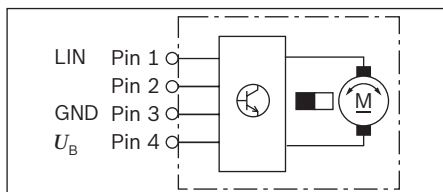
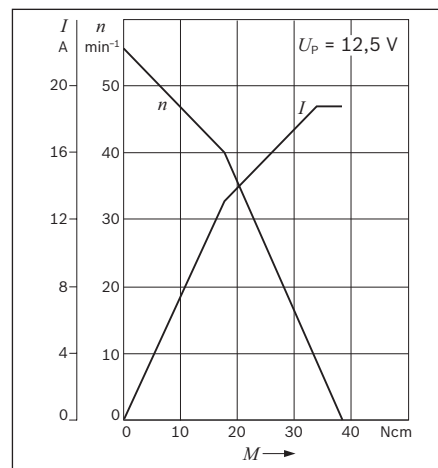

# WDD

with Hall sensor

## 12 V 22 W

Part number	<b>0 390 248 015</b>
Nominal voltage	$U_N$ 12 V
Nominal power	$P_N$ 22 W
Nominal current	$I_N$ 2,9 A
Maximum current	$I_{max}$ 19 A
Nominal speed	$n_N$ 53 min <sup>-1</sup>
Nominal torque	$M_N$ 4 Nm
Breakaway torque	$M_A$ 38 Nm
Reduction	i 1 : 76
Direction of rotation	L/R
Type of duty	S1
Degree of protection	IP6K7
Weight	approx. 1,25 kg

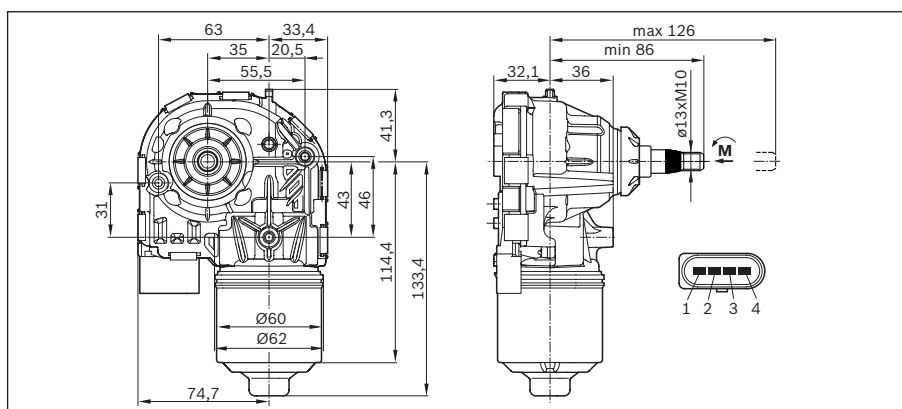
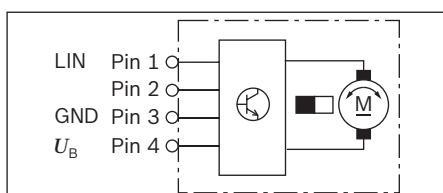
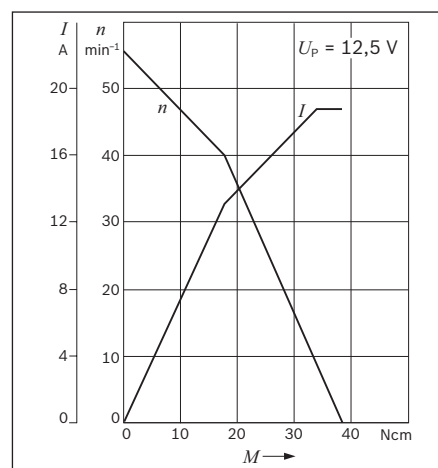

## The VMC flap actuators generation from Bosch



### Advantages for your application

- ▶ Compact and space-saving adjuster drive
- ▶ Robust and reliable quality, well-proven millions of times over in automobiles
- ▶ Favorable price/performance ratio

As comfort requirements on air conditioners increase and the resulting number of air flaps also increase, the number of air-flap actuators also rises. Modern vehicles are equipped with 4–16 air-flap actuators.

### Technology

The flap actuator consists of a permanently-excited D.C. motor and a transmission. The mechanical angle of rotation can be limited by means of stops attached to the housing. The electrical connector is designed for the AMP Micro Quadlock system.

### VMC modular system with:

- ▶ Standard on/off switching
- ▶ Integrated potentiometer
- ▶ Automatic limit stop
- ▶ Output consumption for different positioning elements

### Product features

- ▶ Nominal torque = 0.35 – 0,4 Ncm
- ▶ Breakaway torque = 0.7 – 1.2 Ncm
- ▶ Nominal speed = 4.5 – 7.0 rpm ( $\text{min}^{-1}$ )
- ▶ Nominal voltage = 12/24 V – 1.2 Ncm

In many applications outside the automobile too, exact flap and valve positioning is required. This is why Bosch VMC motors are ideal for your concept.

### Application examples

The VMC air-flap positioner is used for positioning flaps during climate control in automobiles. It is also ideally suited for industrial applications such as valve positioning for water, oil, gas or for instance, for proportioning air quantities in solariums. Bring your idea and application along to us. Together we will get your project moving – with electric motors from Bosch.



VMC with potentiometer

# VMC

with potentiometer

**24 V 0.22 W**

Part number	<b>0 132 801 141</b>
Nominal voltage	$U_N$ 24 V
Nominal power	$P_N$ 0,22 W
Nominal current	$I_N$ ≤ 55 mA
Maximum current	$I_{max}$ 250 mA

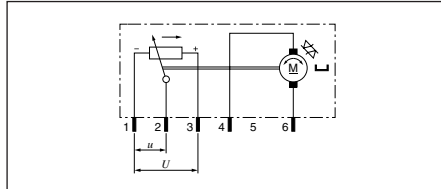

Nominal speed	$n_N$ 6 min <sup>-1</sup>
Nominal torque	$M_N$ 40 Ncm
Breakaway torque	$M_A$ ≥ 140 Ncm
Reduction	$i$ 405 : 1
Direction of rotation	L/R
Shaft load	
max. axial	$F_a$ ≤ 30 N
Shaft load	
max. radial	$F_r$ ≤ 50 N
Type of duty	S 1
Degree of protection	IP 54
Weight	approx. 0,12 kg

Clockwise: 4 to (+), 6 to (-)  
 Anti-clockwise: 6 to (+), 4 to (-)

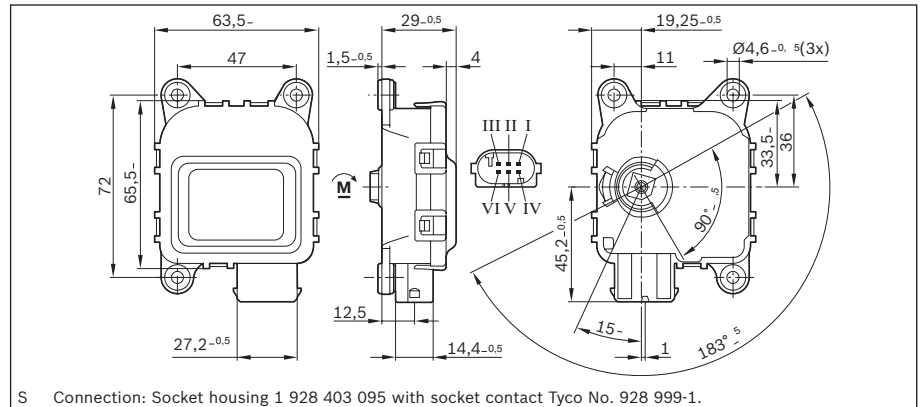
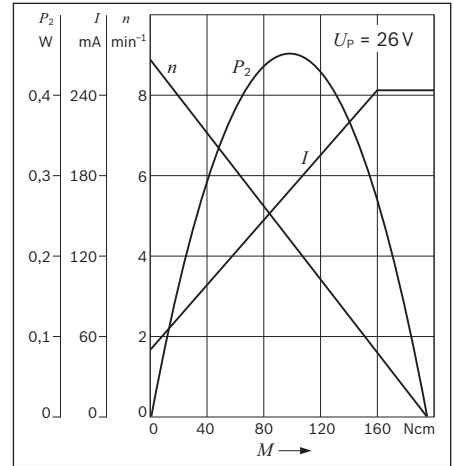

# VMC

**12 V 0.29 W**

Part number	<b>0 132 801 142</b>
Nominal voltage	$U_N$ 12 V
Nominal power	$P_N$ 0,29 W
Nominal current	$I_N$ ≤ 180 mA

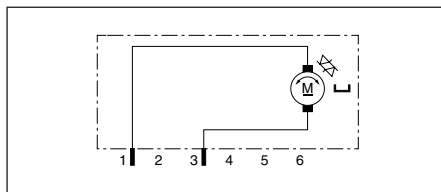

Maximum current	$I_{max}$ 400 mA
Nominal speed	$n_N$ 7 min <sup>-1</sup>
Nominal torque	$M_N$ 40 Ncm
Breakaway torque	$M_A$ ≥ 90 Ncm
Reduction	$i$ 310 : 1
Direction of rotation	L/R
Shaft load	
max. axial	$F_a$ ≤ 30 N
Shaft load	
max. radial	$F_r$ ≤ 50 N
Type of duty	S 1
Degree of protection	IP 40
Weight	approx. 0,12 kg

Clockwise: 1 to (+), 3 to (-)  
 Anti-clockwise: 1 to (-), 3 to (+)

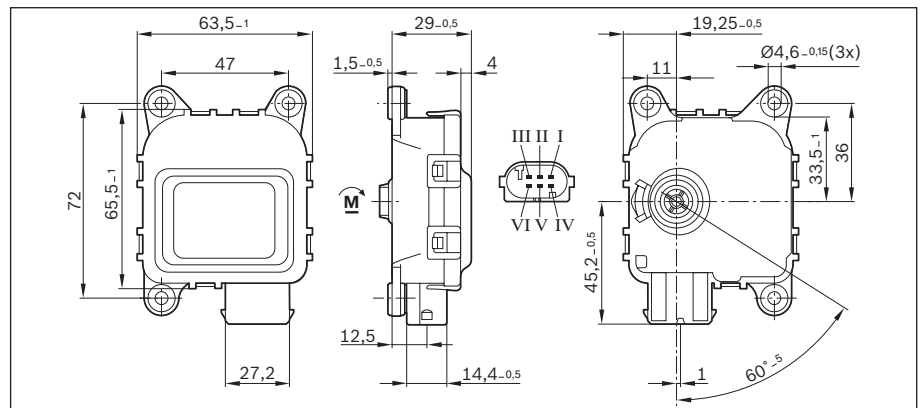
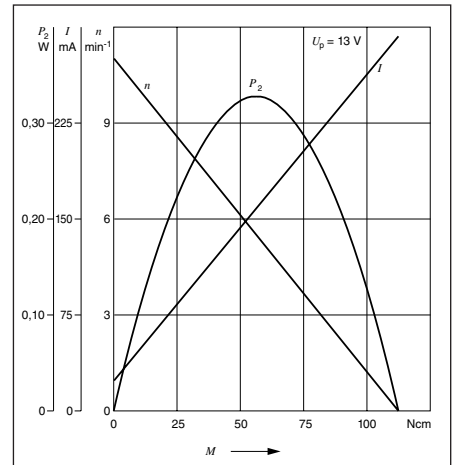



# VMC

## 24 V 0.26 W

Part number	<b>0 132 801 143</b>
Nominal voltage	$U_N$ 24 V
Nominal power	$P_N$ 0,26 W
Nominal current	$I_N$ ≤ 100 mA
Maximum current	$I_{max}$ 200 mA

Nominal speed	$n_N$ 7 min <sup>-1</sup>
Nominal torque	$M_N$ 35 Ncm
Breakaway torque	$M_A$ ≥ 90 Ncm
Reduction	$i$ 310 : 1
Direction of rotation	L/R
Shaft load max. axial	$F_a$ ≤ 30 N
Shaft load max. radial	$F_r$ ≤ 50 N
Type of duty	S 1
Degree of protection	IP 40
Weight	approx. 0,12 kg

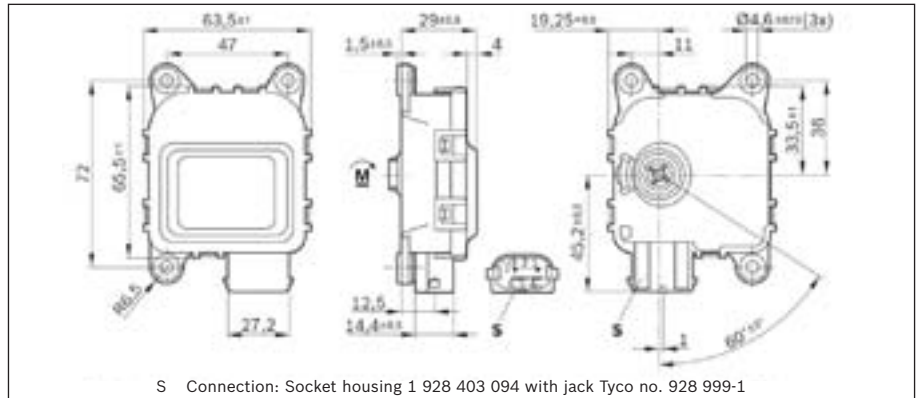
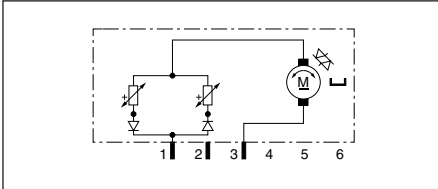
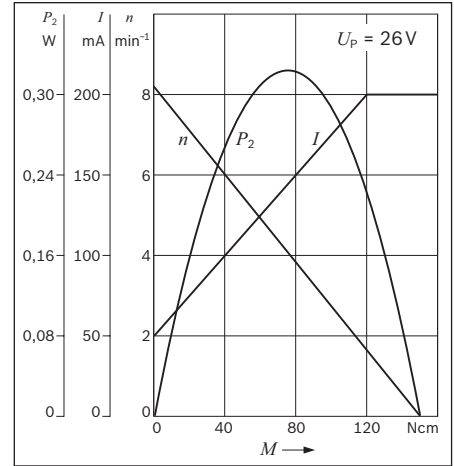

# VMC

## 12 V 0.16 W

Part number	<b>0 132 801 346</b>
Nominal voltage	$U_N$ 12 V
Nominal power	$P_N$ 0,16 W
Nominal current	$I_N$ ≤ 150 mA

Maximum current	$I_{max}$ ≤ 270 mA
Nominal speed	$n_N$ 4,5 min <sup>-1</sup>
Nominal torque	$M_N$ 35 Ncm
Breakaway torque	$M_A$ ≥ 120 Ncm
Reduction	$i$ 450 : 1
Direction of rotation	L/R
Shaft load max. axial	$F_a$ ≤ 30 N
Shaft load max. radial	$F_r$ ≤ 50 N
Type of duty	S 1
Degree of protection	IP 50
Weight	approx. 0,09 kg

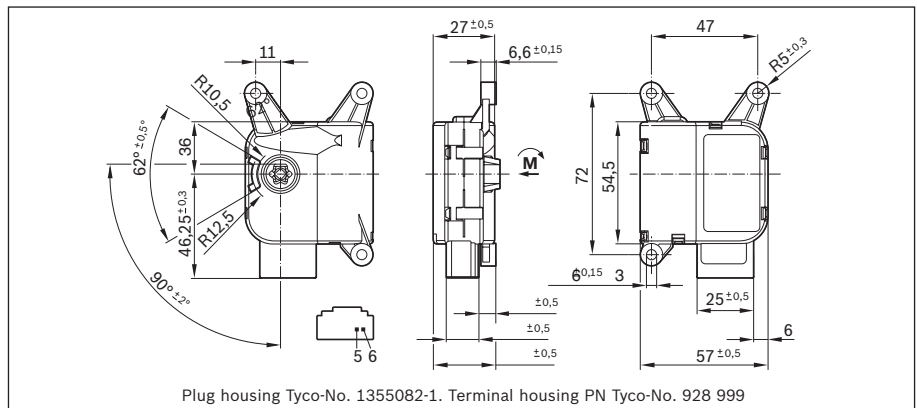
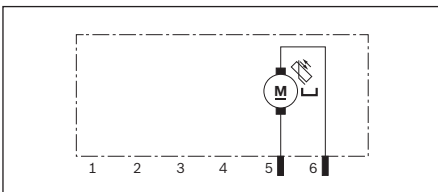
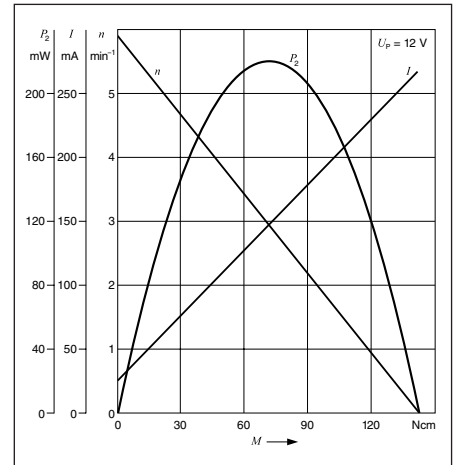

**VMC**

with potentiometer

**12 V 0.16 W**

Part number	<b>0 132 801 347</b>
Nominal voltage	$U_N$ 12 V
Nominal power	$P_N$ 0,16 W
Nominal current	$I_N \leq 150$ mA
Maximum current	$I_{max} \leq 270$ mA
Nominal speed	$n_N$ 4,5 min <sup>-1</sup>
Nominal torque	$M_N$ 35 Ncm
Breakaway torque	$M_A \geq 120$ Ncm
Reduction	i 450 : 1
Direction of rotation	L/R
Shaft load max.axial	$F_a \leq 30$ N
Shaft load max. radial	$F_r \leq 50$ N
Type of duty	S 1
Degree of protection	IP 50
Weight	approx. 0,09 kg

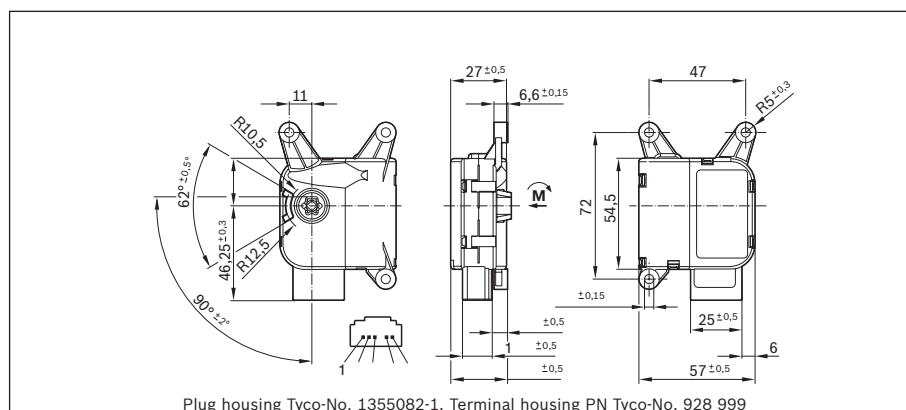
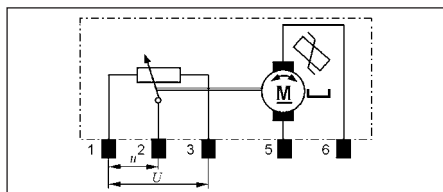
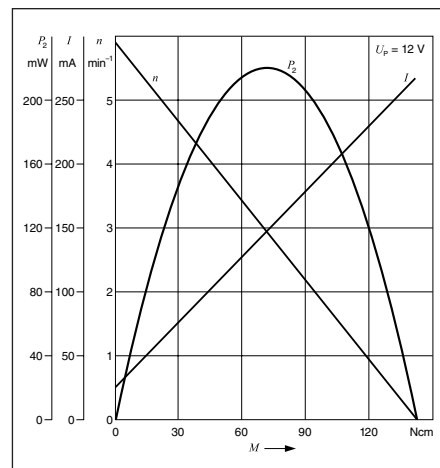

## D.C. motors without transmission



### Product features

- ▶ Wide range of permanent-magnet D.C. motor products
- ▶ D.C. voltage range from 12 to 24 Volt
- ▶ Nominal speed range from 2840 to 5000 rpm ( $\text{min}^{-1}$ )
- ▶  $P_{\text{output max.}} = 180 - 300 \text{ W}$

### Advantages for your application

- ▶ Robust and reliable quality, well-proven in many millions of motor vehicles
- ▶ High reliability and service life
- ▶ A multitude of different sizes and designs for greater flexibility
- ▶ Favorable price/performance ratio

The Bosch D.C. motors without transmission referred to here are permanent-magnet D.C. motors developed for use in motor vehicles. They excel on account of an excellent power/weight ratio, and a broad working range in different requirements and installation situations.

Bosch electric motors without transmission are typically used in motor vehicles as a motor for heater or air-conditioning devices or for power-seat adjustment. The installation position can vary arbitrarily from horizontal to vertical. Bosch electric motors without transmission, are also the suitable solution for many applications outside the automobile.

### Application examples

#### Automotive technology:

Heater and air-conditioning blowers, engine cooling, power-seat adjustment

#### Industrial applications:

Electric mopeds, sweeping machines and lots more



# API

## 12 V 29 W

Part number	<b>0 130 002 525</b>
Nominal voltage	$U_N$ 12 V
Nominal power	$P_N$ 29 W
Nominal current	$I_N$ 7,0 A
Nominal speed	$n_N$ 3100 min <sup>-1</sup>
Nominal torque	$M_N$ 9 Ncm
Breakaway torque	$M_A$ 31 Ncm
Direction of rotation	L/R
Type of duty	S 3 - 15 %
Degree of protection	IP 50 A
Weight	approx. 0,44 kg

Clockwise: I to term (+), II to term (-)  
 Anti-clockwise: I to term (-), II to term (+)

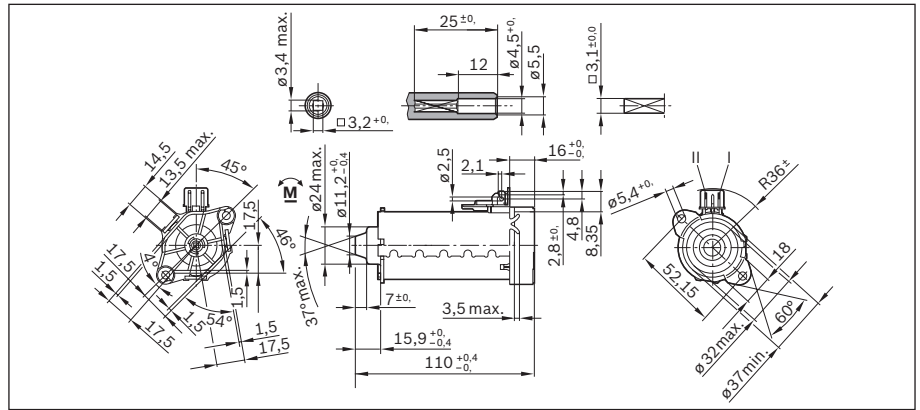
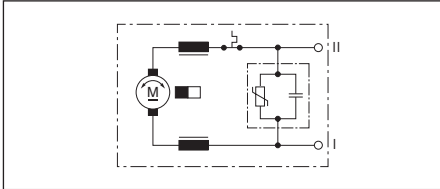
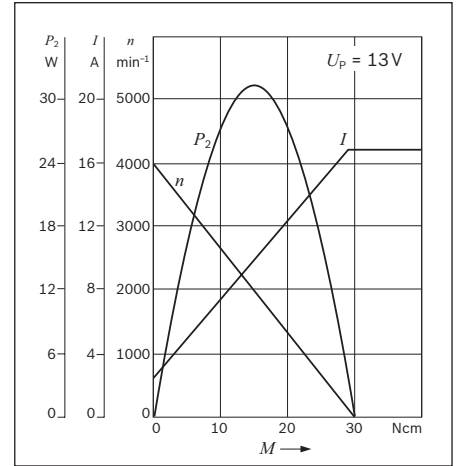

# API

## with Hall sensor

## 12 V 29 W

Part number	<b>0 130 002 527</b>
Nominal voltage	$U_N$ 12 V
Nominal power	$P_N$ 29 W
Nominal current	$I_N$ 7,0 A
Nominal speed	$n_N$ 3100 min <sup>-1</sup>
Nominal torque	$M_N$ 9 Ncm
Breakaway torque	$M_A$ 31 Ncm
Direction of rotation	L/R
Type of duty	S 3 - 15 %
Degree of protection	IP 50 A
Weight	approx. 0,44 kg

Clockwise: I to term (+), II to term (-)  
 Anti-clockwise: I to term (-), II to term (+)

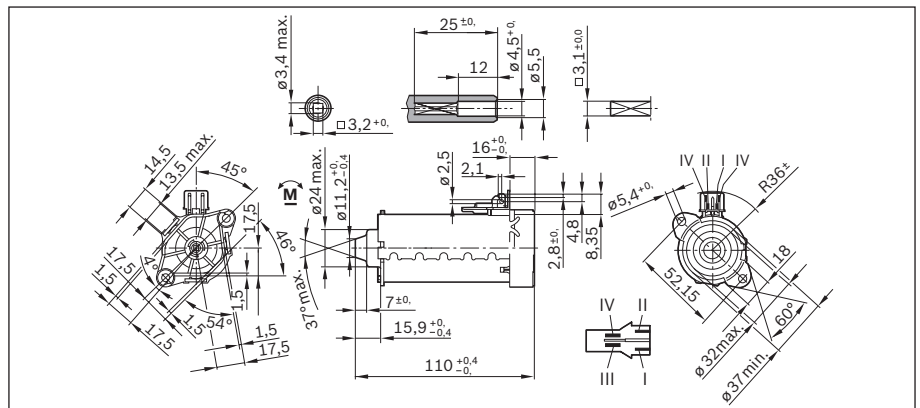
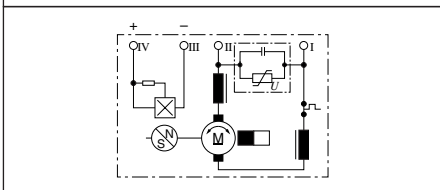
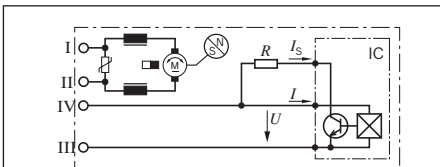
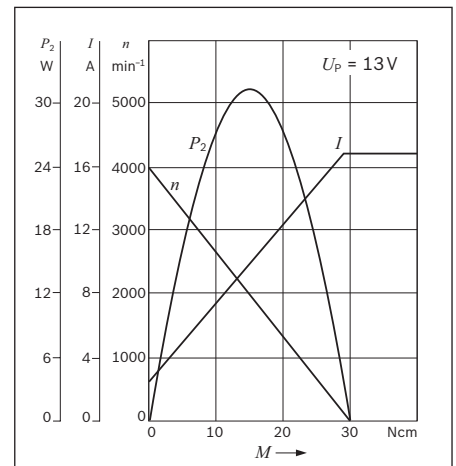

## API

### 12 V 46 W

Part number	<b>0 130 002 529</b>
Nominal voltage	$U_N$ 12 V
Nominal power	$P_N$ 46 W
Nominal current	$I_N$ 9,0 A
Nominal speed	$n_N$ 2900 min <sup>-1</sup>
Nominal torque	$M_N$ 15 Ncm
Breakaway torque	$M_A$ 48,5 Ncm
Direction of rotation	L/R
Type of duty	S 3 - 15 %
Degree of protection	IP 50
Weight	approx. 0,44 kg

Clockwise: I to term (+), II to term (-)  
 Anti-clockwise: I to term (-), II to term (+)

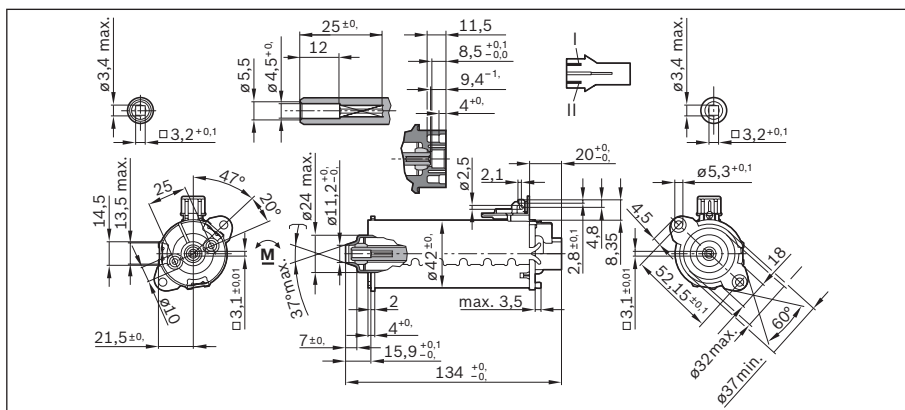
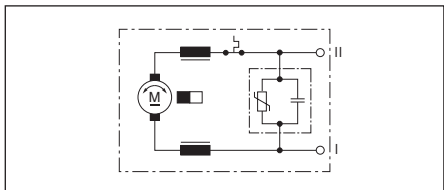
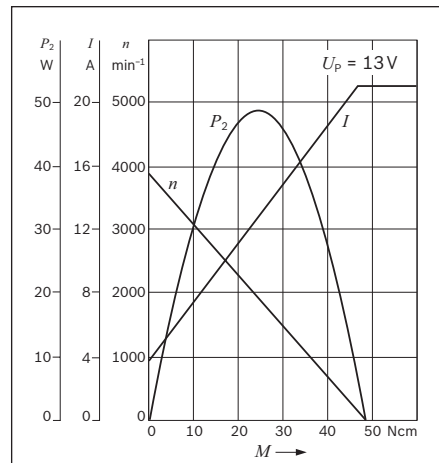

## API

### with Hall sensor

### 12 V 46 W

Part number	<b>0 130 002 530</b>
Nominal voltage	$U_N$ 12 V
Nominal power	$P_N$ 46 W
Nominal current	$I_N$ 9,0 A
Nominal speed	$n_N$ 2900 min <sup>-1</sup>
Nominal torque	$M_N$ 15 Ncm
Breakaway torque	$M_A$ 48,5 Ncm
Direction of rotation	L/R
Type of duty	S 3 - 15 %
Degree of protection	IP 50
Weight	approx. 0,44 kg

Clockwise: I to term (+), II to term (-)  
 Anti-clockwise: I to term (-), II to term (+)

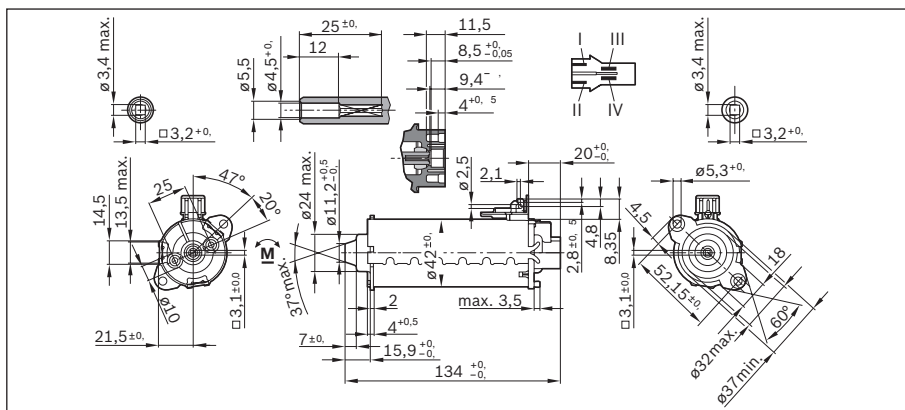
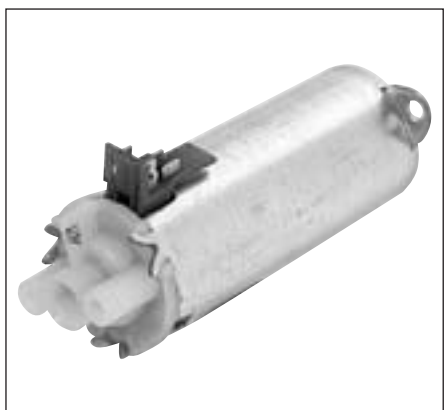
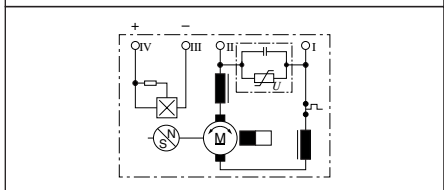
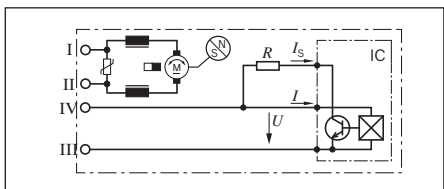
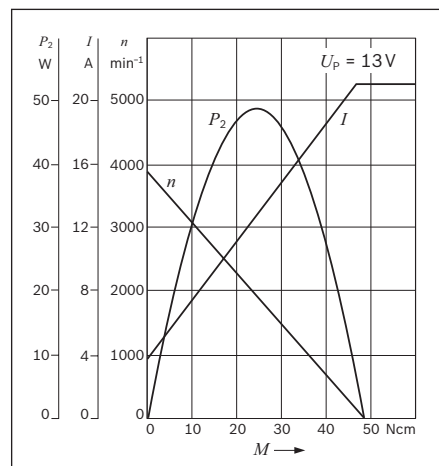

# API

## 24 V 25 W

Part number	<b>0 130 002 562</b>
Nominal voltage	$U_N$ 24 V
Nominal power	$P_N$ 25 W
Nominal current	$I_N$ 2,7 A
Nominal speed	$n_N$ 2950 min <sup>-1</sup>
Nominal torque	$M_N$ 8 Ncm
Breakaway torque	$M_A$ 30 Ncm
Direction of rotation	L/R
Type of duty	S 3 - 15 %
Degree of protection	IP 50
Weight	approx. 0,55 kg

Clockwise: red (rt) to term (+),  
brown (br) to term (-)  
Anti-clockwise: red (rt) to term (-),  
brown (br) to term (+)

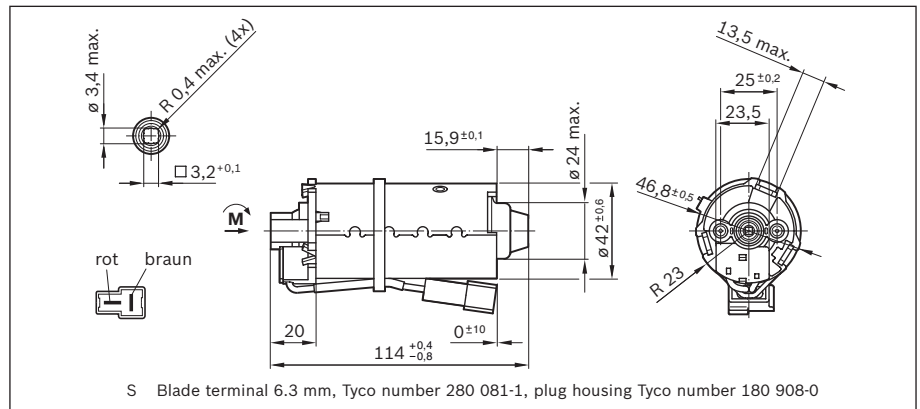
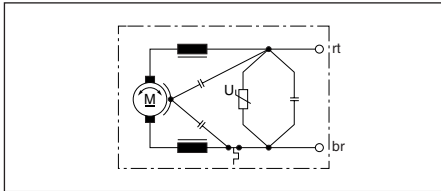
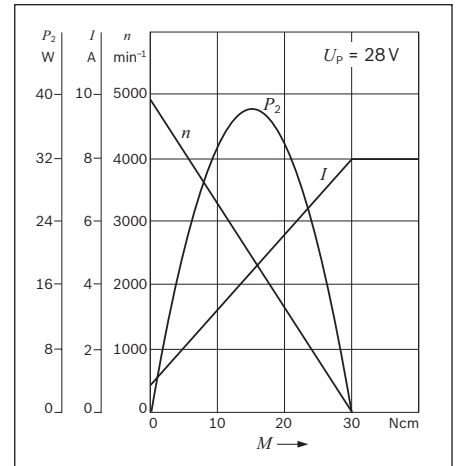

# API

## with Hall sensor

## 12 V 29.2 W

Part number	<b>0 130 002 613</b>
Nominal voltage	$U_N$ 12 V
Nominal power	$P_N$ 29,2 W
Nominal current	$I_N$ 5,8 A
Nominal speed	$n_N$ 2790 min <sup>-1</sup>
Nominal torque	$M_N$ 10 Ncm
Breakaway torque	$M_A$ 69 Ncm
Direction of rotation	L/R
Type of duty	S 3 - 15 %
Degree of protection	IP 50
Weight	approx. 0,60 kg

Clockwise: I to term (+) II to term (-)  
Anti-clockwise: I to term (-) II to term (+)

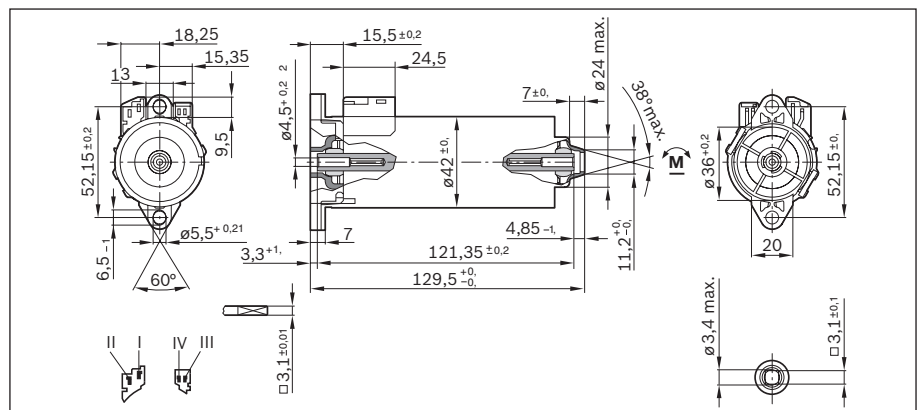
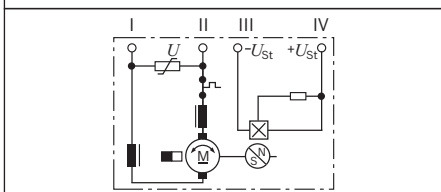
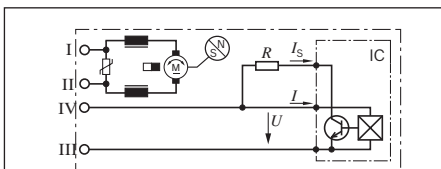
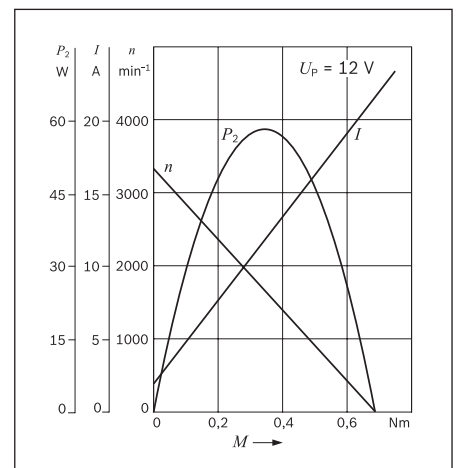



# API

## with Hall sensor

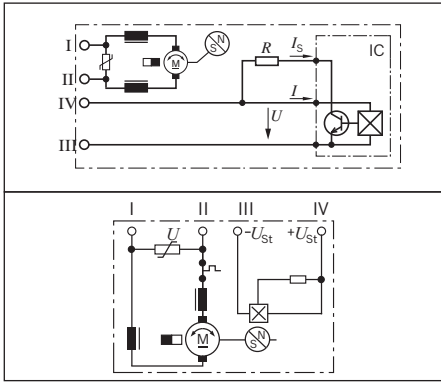

### 12 V 35.2 W

Part number	<b>0 130 002 632</b>
Nominal voltage	$U_N$ 12 V
Nominal power	$P_N$ 35,2 W
Nominal current	$I_N$ 6,8 A
Nominal speed	$n_N$ 3360 min <sup>-1</sup>
Nominal torque	$M_N$ 10 Ncm
Breakaway torque	$M_A$ 49 Ncm
Direction of rotation	L/R
Type of duty	S 3 - 15 %
Degree of protection	IP 50
Weight	approx. 0,45 kg

Clockwise: I to term (+), II to term (-)  
 Anti-clockwise: I to term (-), II to term (+)

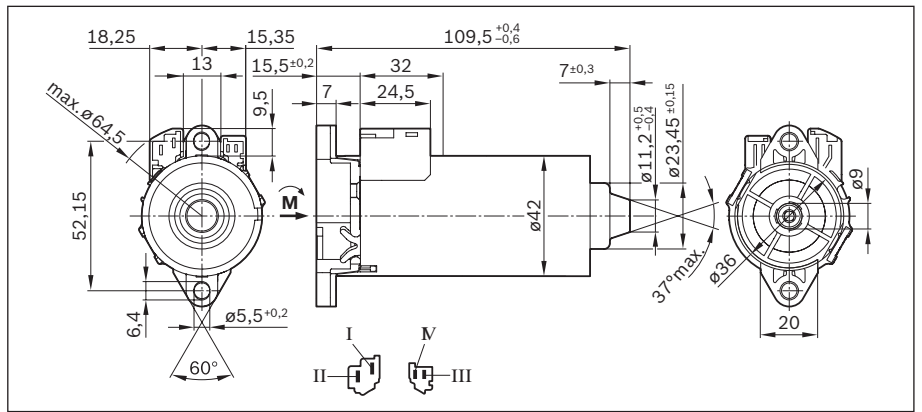
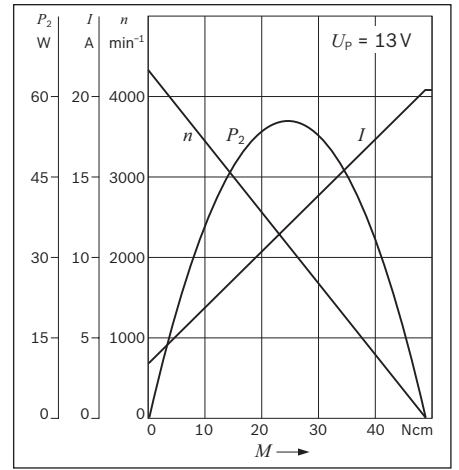

# API

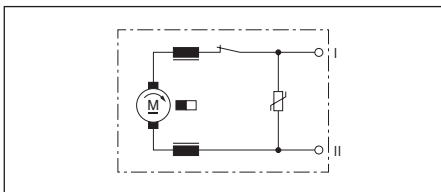

### 12 V 35.2 W

Part number	<b>0 130 002 633</b>
Nominal voltage	$U_N$ 12 V
Nominal power	$P_N$ 35,2 W
Nominal current	$I_N$ 6,8 A
Nominal speed	$n_N$ 3360 min <sup>-1</sup>
Nominal torque	$M_N$ 10 Ncm
Breakaway torque	$M_A$ 49 Ncm
Direction of rotation	L/R
Type of duty	S 3 - 15 %
Degree of protection	IP 50
Weight	approx. 0,45 kg

Clockwise: I to term (+), II to term (-)  
 Anti-clockwise: I to term (-), II to term (+)

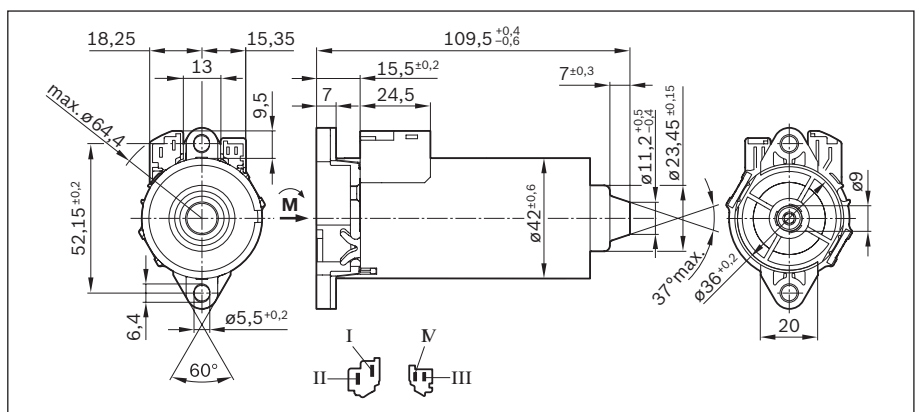
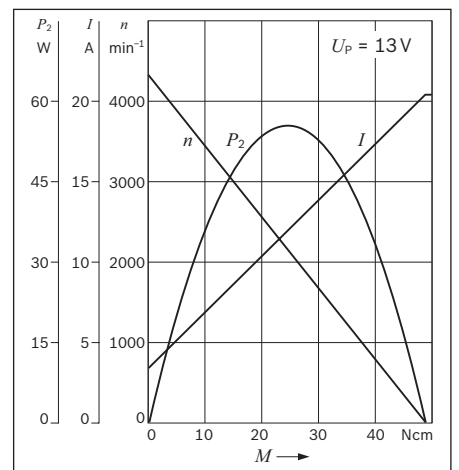

## API with Hall sensor

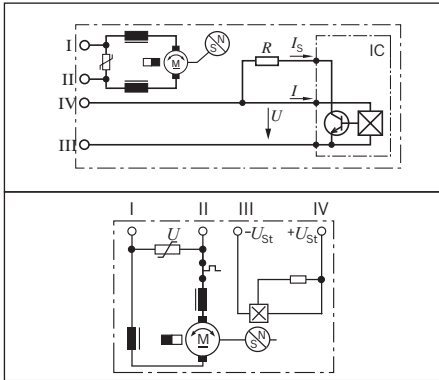

### 12 V 36.4 W

Part number	<b>0 130 002 634</b>
Nominal voltage	$U_N$ 12 V
Nominal power	$P_N$ 36,4 W
Nominal current	$I_N$ 6,3 A
Nominal speed	$n_N$ 3480 min <sup>-1</sup>
Nominal torque	$M_N$ 10 Ncm
Breakaway torque	$M_A$ 62 Ncm
Direction of rotation	L/R
Type of duty	S 3 - 15 %
Degree of protection	IP 50
Weight	approx. 0,53 kg

Clockwise: I to term (+), II to term (-)  
Anti-clockwise: I to term (-), II to term (+)

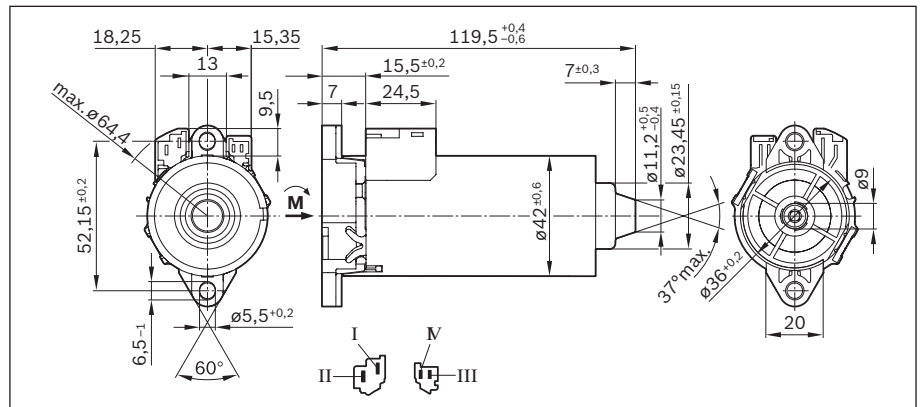
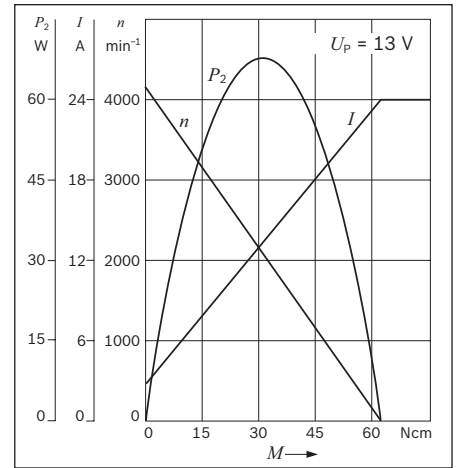

## API

### 12 V 29.2 W

Part number	<b>0 130 002 636</b>
Nominal voltage	$U_N$ 12 V
Nominal power	$P_N$ 29,2 W
Nominal current	$I_N$ 5,8 A
Nominal speed	$n_N$ 2790 min <sup>-1</sup>
Nominal torque	$M_N$ 10 Ncm
Breakaway torque	$M_A$ 69 Ncm
Direction of rotation	L/R
Type of duty	S 3 - 15 %
Degree of protection	IP 50
Weight	approx. 0,60 kg

Clockwise: I to term (+), II to term (-)  
Anti-clockwise: I to term (-), II to term (+)

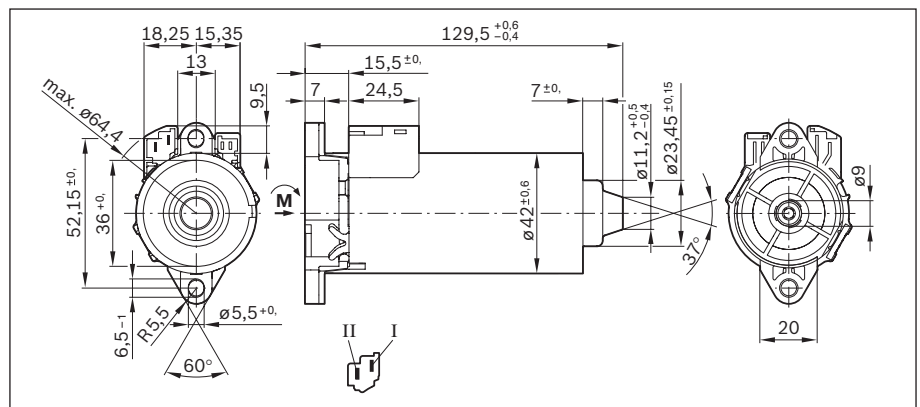
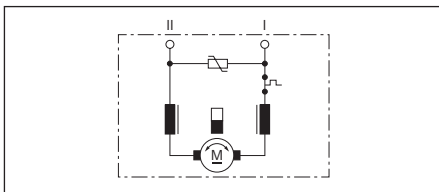
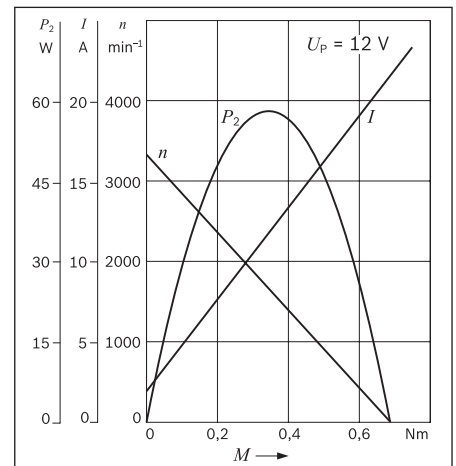

# API

## 24 V 46 W

Part number	<b>0 130 002 671</b>
Nominal voltage	$U_N$ 24 V
Nominal power	$P_N$ 46 W
Nominal current	$I_N$ 4,5 A
Nominal speed	$n_N$ 2900 min <sup>-1</sup>
Nominal torque	$M_N$ 15 Ncm
Breakaway torque	$M_A$ 66 Ncm
Direction of rotation	L/R
Type of duty	S 3 - 15 %
Degree of protection	IP 50
Weight	approx. 0,57 kg

Clockwise: I to term (+) II to term (-)  
 Anti-clockwise: I to (-) II to (+)

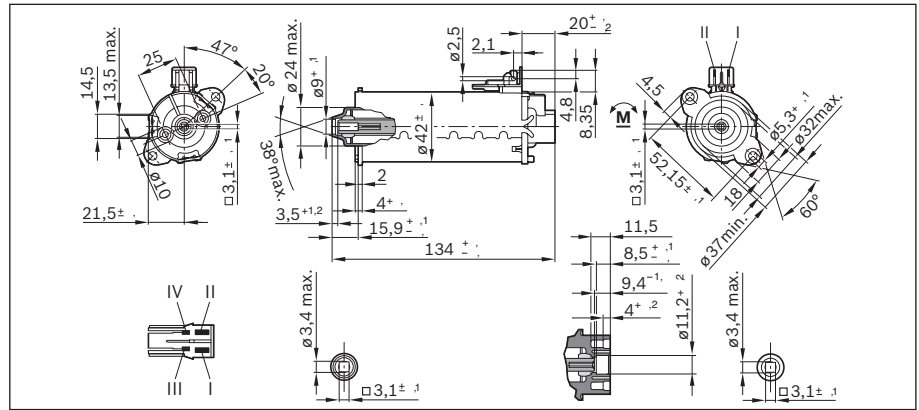
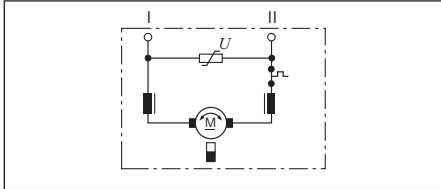
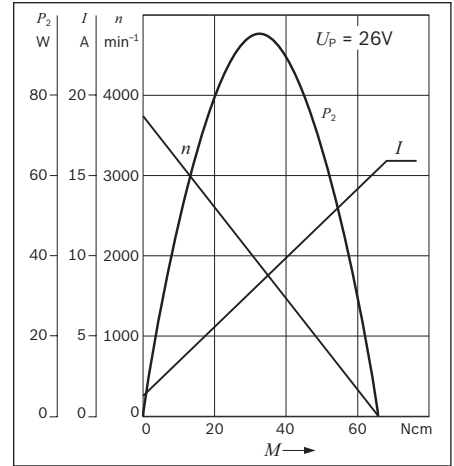

# API

## 24 V 29.2 W

Part number	<b>0 130 002 674</b>
Nominal voltage	$U_N$ 24 V
Nominal power	$P_N$ 29,2 W
Nominal current	$I_N$ 2,9 A
Nominal speed	$n_N$ 2790 min <sup>-1</sup>
Nominal torque	$M_N$ 10 Ncm
Breakaway torque	$M_A$ 65 Ncm
Direction of rotation	L/R
Type of duty	S 3 - 15 %
Degree of protection	IP 50
Weight	approx. 0,60 kg

<sup>1)</sup> On request  
 Clockwise: I to term (+) II to term (-)  
 Anti-clockwise: I to term (-) II to term (+)

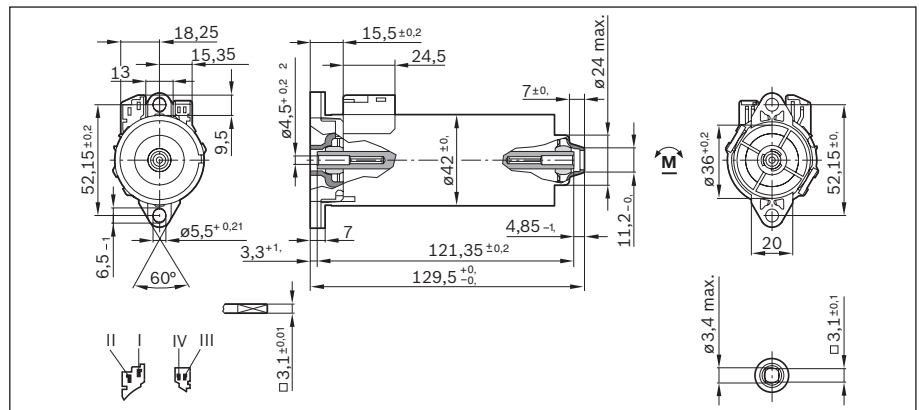
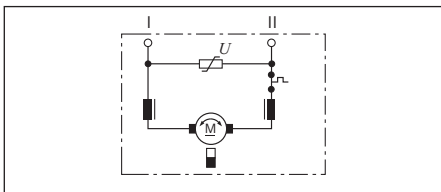
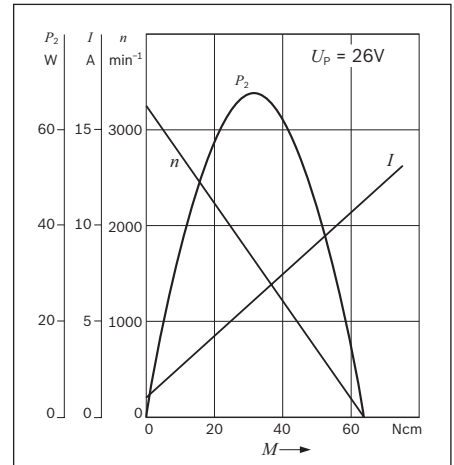

## NSA-I

Similar to original picture  
with Hall sensor

### 12 V 23 W

Part number	<b>0 390 204 092</b>
Nominal voltage	$U_N$ 12 V
Nominal power	$P_N$ 23 W
Nominal current	$I_N$ 5 A
Nominal speed	$n_N$ 2000 min <sup>-1</sup>
Nominal torque	$M_N$ 0,11 Nm
Breakaway torque	$M_A$ 0,53 Nm
Direction of rotation	L/R
Type of duty	S 3
Degree of protection	IP 50
Weight	approx. 0,34 kg

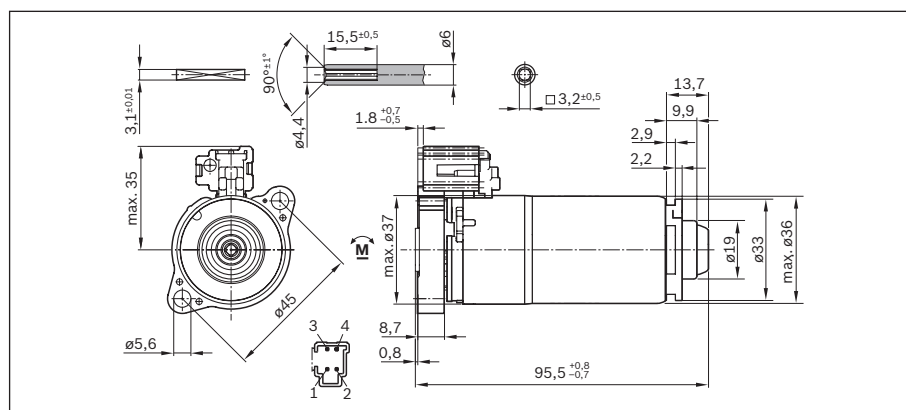
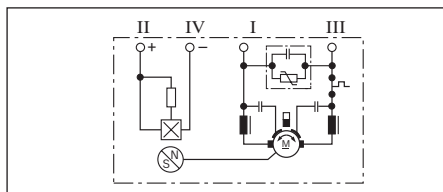
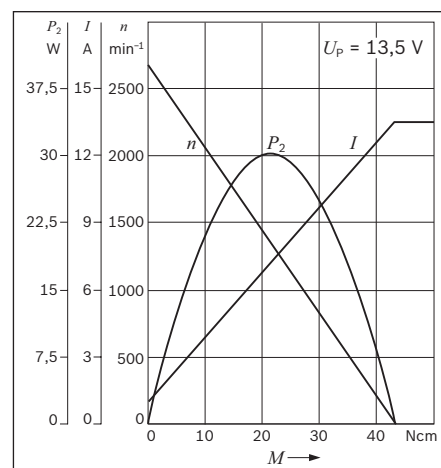

# CPB

## 24 V 60 W

Part number	<b>0 986 338 100</b>
Nominal voltage	$U_N$ 24 V
Nominal power	$P_N$ 60 W
Nominal current	$I_N$ 4,0 A
Nominal speed	$n_N$ 3950 min <sup>-1</sup>
Nominal torque	$M_N$ 15 Ncm
Breakaway torque	$M_A$ 150 Ncm
Direction of rotation	L/R
Type of duty	S1
Weight	approx. 0,80 kg

Clockwise: I on (+) II on (-)  
 Anti-clockwise: I on (-) II on (+)

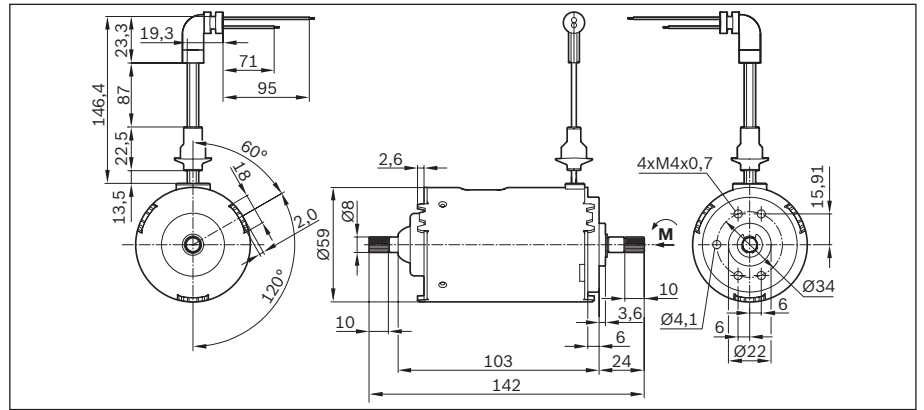
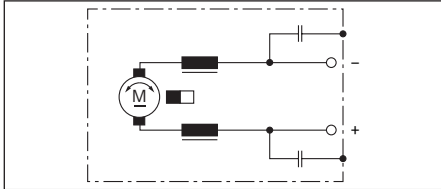
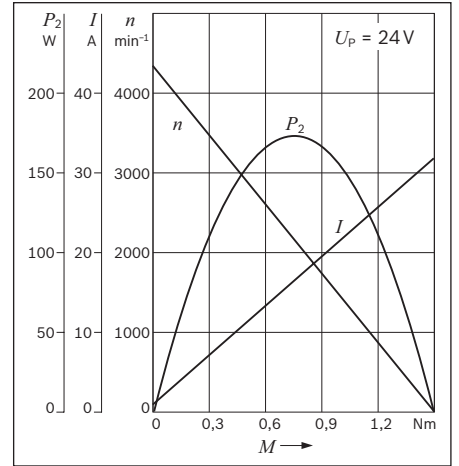

## DPO-L

Similar to original picture

### 24 V 185 W

Part number	<b>0 130 101 516</b>
Nominal voltage	$U_N$ 24 V
Nominal power	$P_N$ 185 W
Nominal current	$I_N$ 12,0 A
Nominal speed	$n_N$ 5000 min <sup>-1</sup>
Nominal torque	$M_N$ 35 Ncm
Breakaway torque	$M_A$ 250 Ncm
Direction of rotation	R
Operating mode	S 1
Degree of protection	IP 10
Weight	approx. 1,30 kg

Clockwise rotation: I an (+) II an (-)  
 Counter-clockwise rotation: I an (-) II an (+)

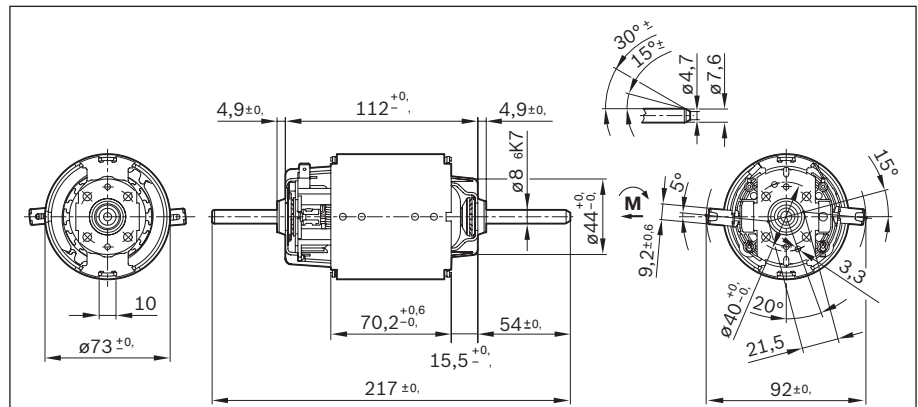
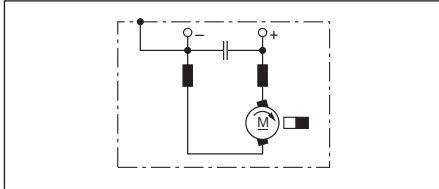
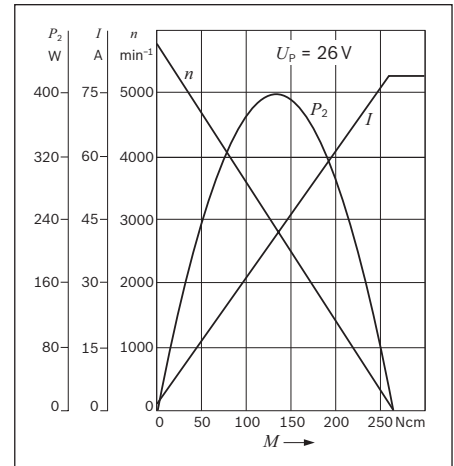

## DPO-K

Similar to original picture

### 24 V 180 W

Part number	<b>0 130 101 616</b>
Nominal voltage	$U_N$ 24 V
Nominal power	$P_N$ 180 W
Nominal current	$I_N$ 12,5 A
Nominal speed	$n_N$ 4300 min <sup>-1</sup>
Nominal torque	$M_N$ 40 Ncm
Breakaway torque	$M_A$ 160 Ncm
Direction of rotation	R
Operating mode	S 1
Degree of protection	IP 10
Weight	approx. 1,10 kg

Clockwise rotation: I to (+), II to (-)  
 Counter-clockwise rotation: I to (-), II to (+)

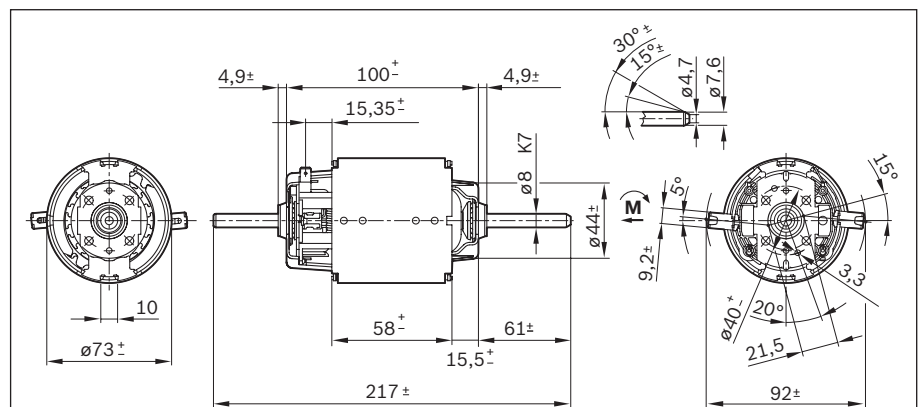
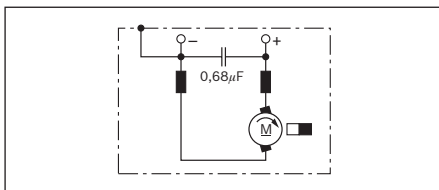
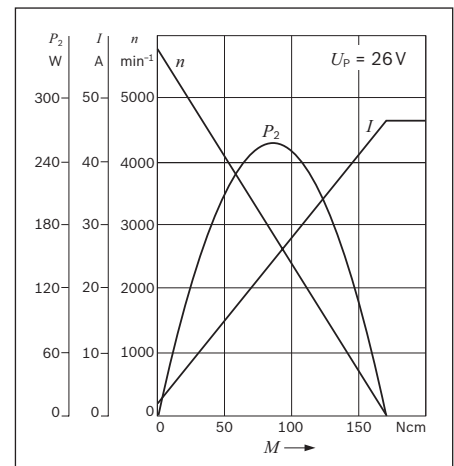



## GPG-M

Similar to original picture

### 12 V 198 W

Part number	<b>3 137 230 005</b>
Nominal voltage	$U_N$ 12 V
Nominal power	$P_N$ 198 W
Nominal current	$I_N$ 22,0 A
Nominal speed	$n_N$ 2250 min <sup>-1</sup>
Nominal torque	$M_N$ 84 Ncm
Direction of rotation	R
Type of duty	S 1
Degree of protection	IP 03
Weight	approx. 1,60 kg

On request:  
[contact.i.business@de.bosch.com](mailto:contact.i.business@de.bosch.com)

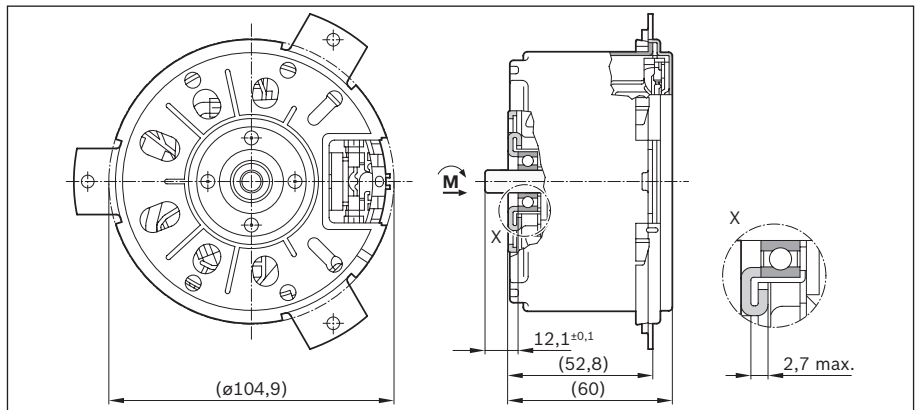
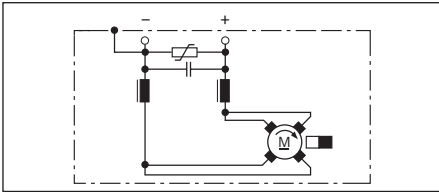

## GPG-M

Similar to original picture

### 12 V 274 W

Part number	<b>3 137 230 006</b>
Nominal voltage	$U_N$ 12 V
Nominal power	$P_N$ 274 W
Nominal current	$I_N$ 30,0 A
Nominal speed	$n_N$ 2490 min <sup>-1</sup>
Nominal torque	$M_N$ 105 Ncm
Direction of rotation	R
Type of duty	S 1
Degree of protection	IP 03
Weight	approx. 1,60 kg

On request:  
[contact.i.business@de.bosch.com](mailto:contact.i.business@de.bosch.com)

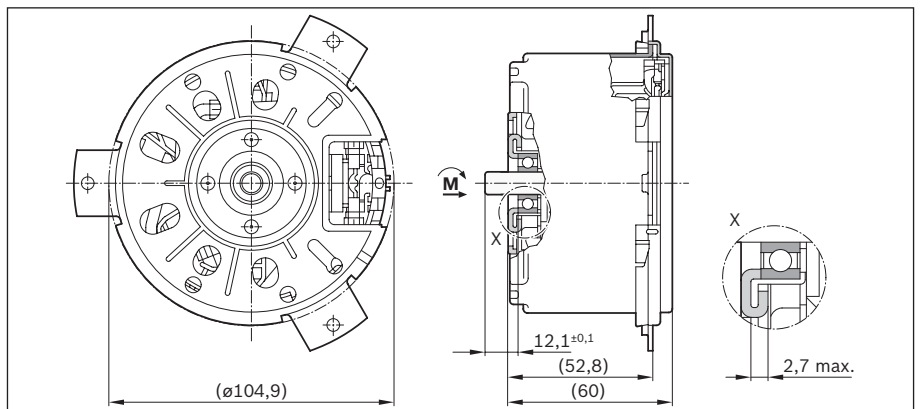
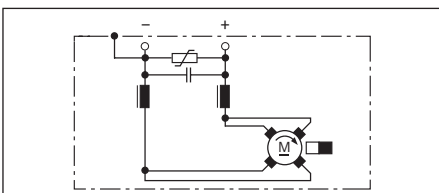

**GBM-M**

Similar to original picture

**12 V 155 W**

Part number	<b>0 130 115 152</b>
Nominal voltage	$U_N$ 12 V
Nominal power	$P_N$ 155 W
Nominal current	$I_N$ 19,0 A
Nominal speed	$n_N$ 4000 min <sup>-1</sup>
Nominal torque	$M_N$ 37 Ncm
Breakaway torque	$M_A$ 200 Ncm
Direction of rotation	R
Type of duty	S 1
Degree of protection	IP 10
Weight	approx. 1,10 kg

Clockwise: I to (+), II to (-)  
 Counterclockwise: I to (-), II to (+)

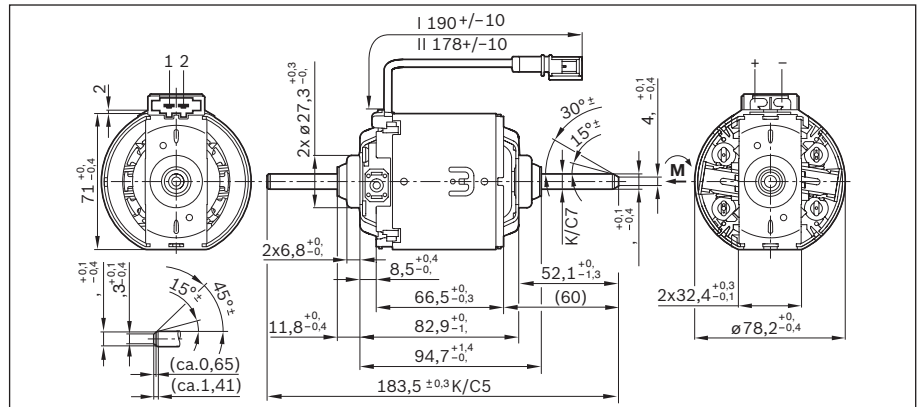
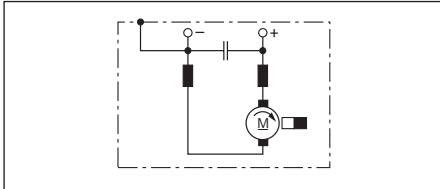
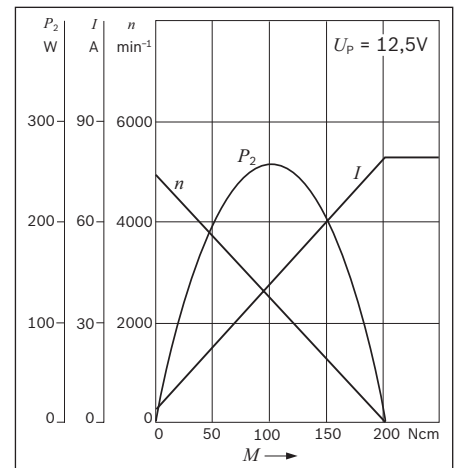
**GBM-M**

Similar to original picture

**12 V 217 W**

Part number	<b>0 130 115 154</b>
Nominal voltage	$U_N$ 12 V
Nominal power	$P_N$ 217 W
Nominal current	$I_N$ 27,6 A
Nominal speed	$n_N$ 4150 min <sup>-1</sup>
Nominal torque	$M_N$ 50 Ncm
Breakaway torque	$M_A$ 220 Ncm
Direction of rotation	R
Type of duty	S 1
Degree of protection	IP 10
Weight	approx. 1,10 kg

Clockwise: I to (+), II to (-)  
 Counterclockwise: I to (-), II to (+)

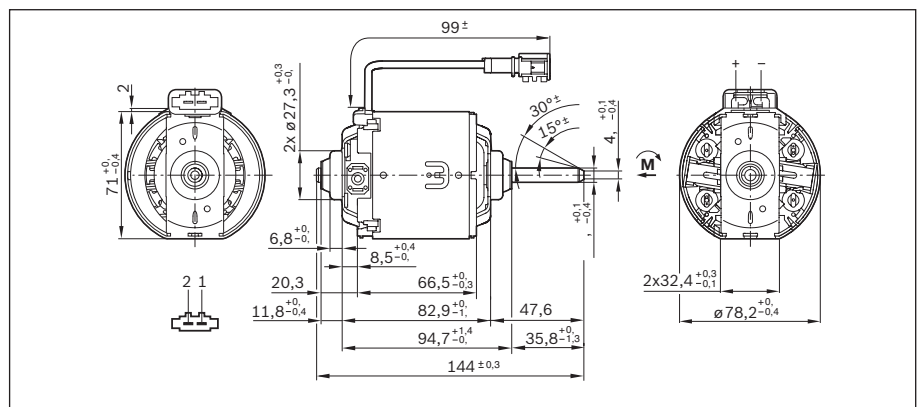
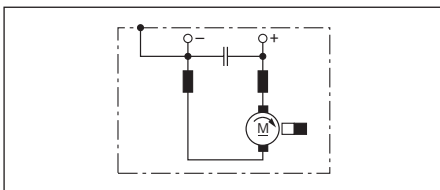
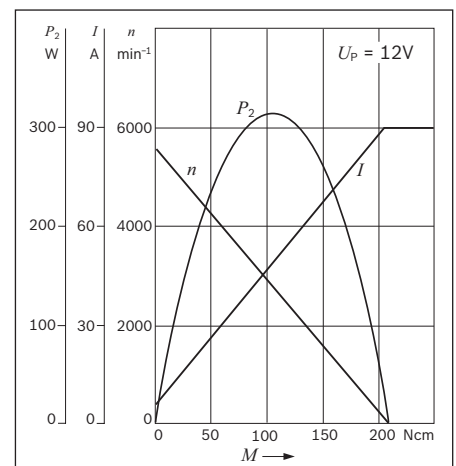

# GBM-L

Similar to original picture

## 12 V 250 W

Part number	<b>0 130 115 352</b>
Nominal voltage	$U_N$ 12 V
Nominal power	$P_N$ 250 W
Nominal current	$I_N$ 28,5 A
Nominal speed	$n_N$ 4340 min <sup>-1</sup>
Nominal torque	$M_N$ 55 Ncm
Breakaway torque	$M_A$ 300 Ncm
Direction of rotation	R
Type of duty	S 1
Degree of protection	IP 10
Weight	approx. 1,40 kg

Clockwise: I to (+), II to (-)  
 Counterclockwise: I to (-), II to (+)

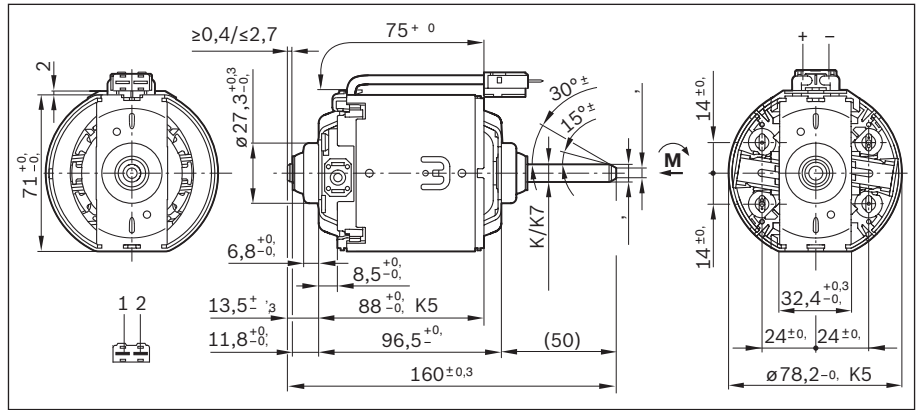
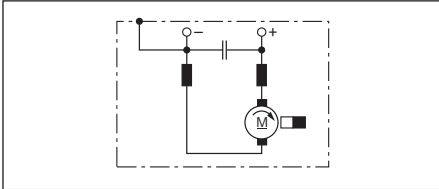
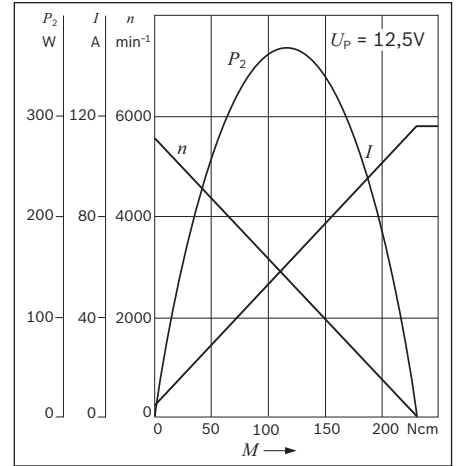



## Blowers with D.C. motors



### Product features

- ▶ Wide range of blowers
- ▶ D.C. voltage range 12 V
- ▶ Axial and radial-type blowers available
- ▶ RPM control

### Advantages for your application

- ▶ Low noise development
- ▶ High efficiency
- ▶ Low weight
- ▶ Favorable price/performance ratio

As the largest manufacturer of electric motors in Europe, Bosch provides a comprehensive range of blower and engine-cooling products for every output range. Our blower range consists of single or multiple-stage suction or pressure blowers. The delivery range encompasses radial and axial-type blowers for 12 V. The blowers are designed for operating mode S1 (continuous operation). The modules are available with brush-type motors or as brushless drives.

The compact design of the modules means that they can be easily installed in areas where space is at a premium.

### Application examples

Heating, ventilation, air-conditioning and engine cooling, cooler blowers in general



**GBM-S**

Similar to original picture

**12 W**

Part number	<b>0 130 115 604</b>
Rated voltage	$U_N$ 12 V
Pressure difference	$\Delta p$ 470 Pa
Speed stage II	$n_{NII}$ 3510 ... 4200 min <sup>-1</sup>
Direction of rotation	R
Operating mode	S1
Degree of protection	IP13
Weight	approx. 1,13 kg

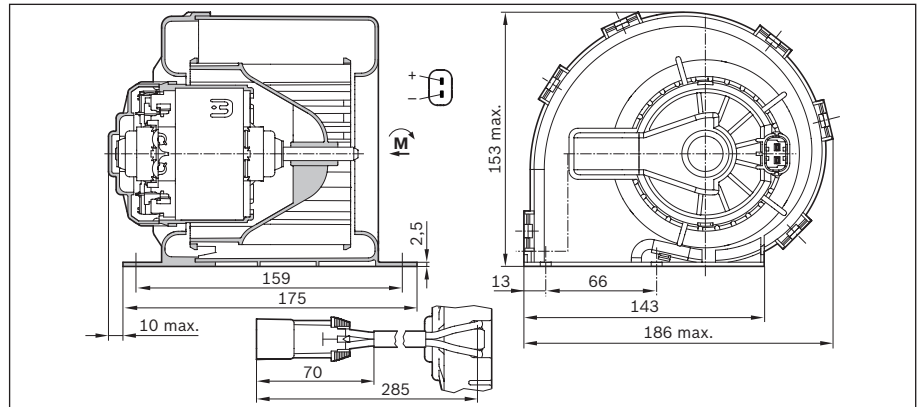
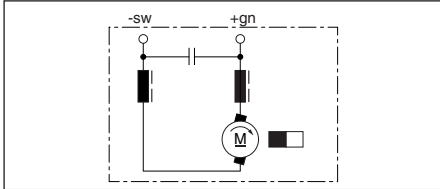
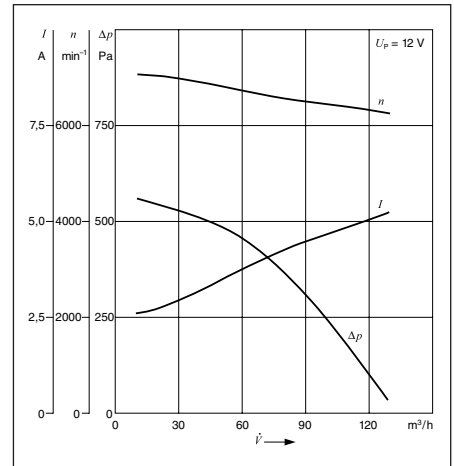



## Solenoid valves



### Valves for water-quantity control

#### Application

Heater control for passenger cars and commercial vehicles.

#### Valve models

The lower valve cone is designed as a non-return valve.

The valves are open when de-energized.

Shutoff- or pulse valve

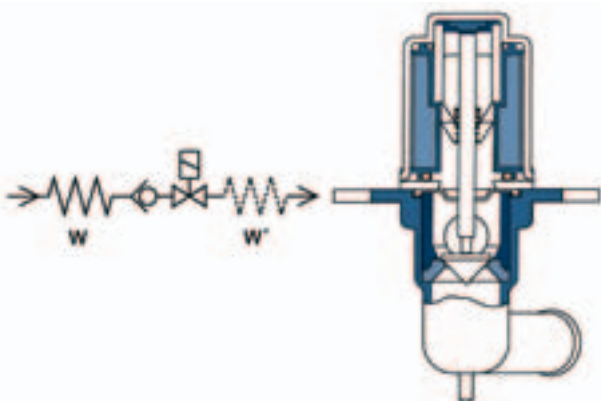

W and W' heat exchanger optionally upstream or downstream of valve

Changeover valve or pulse valve

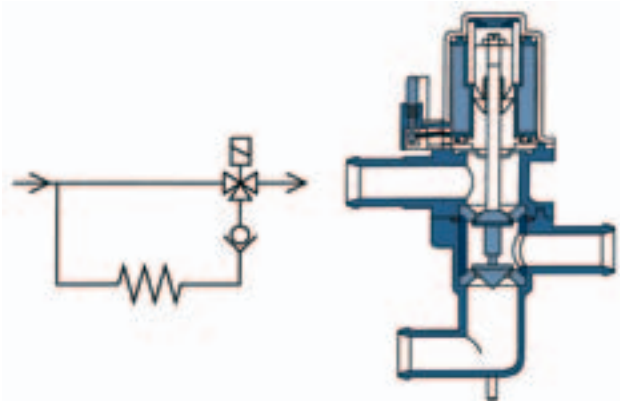

## Shutoff or timing valves

Similar to original picture

### 24 V

Part number	<b>1 147 412 205</b>
Nominal voltage	$U_N$ 24 V
Resistance	$R_{20}$ 48 $\Omega$
Pressure drop	$\Delta p$ 35 kPa
at a throughput of	$\dot{V}$ 2000 dm <sup>3</sup> ·h <sup>-1</sup>
Switchable pressure difference	$\Delta p$ 160 kPa
Switching times	$\leq$ 100 ms
Duty cycle	0 ... 100 %
Degree of protection	IP 5K4
Weight	approx. 386,0 g

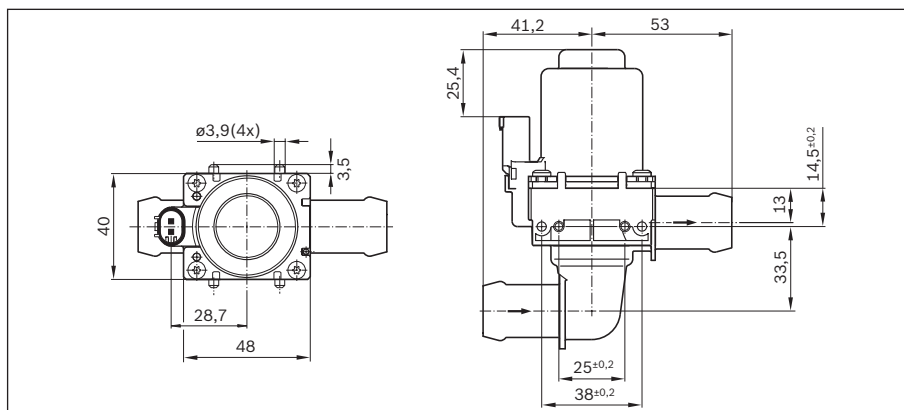
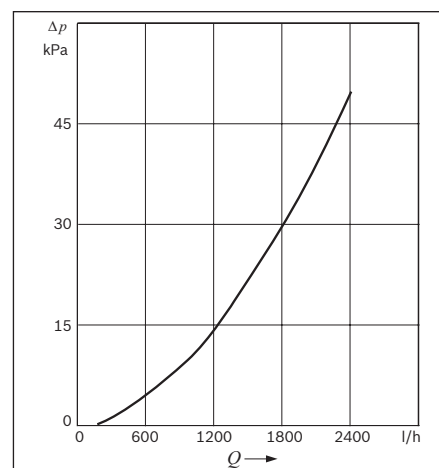
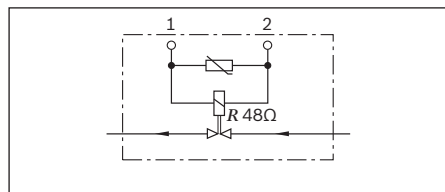

## Shutoff or timing valves

Similar to original picture

### 12 V

Part number	<b>1 147 412 208</b>
Nominal voltage	$U_N$ 12 V
Resistance	$R_{20}$ 12,4 $\Omega$
Pressure drop	$\Delta p$ 35 kPa
at a throughput of	$\dot{V}$ 2000 dm <sup>3</sup> ·h <sup>-1</sup>
Switchable pressure difference	$\Delta p$ 160 kPa
Switching times	$\leq$ 100 ms
Duty cycle	0 ... 100 %
Degree of protection	IP 5K4
Weight	approx. 0,4 g

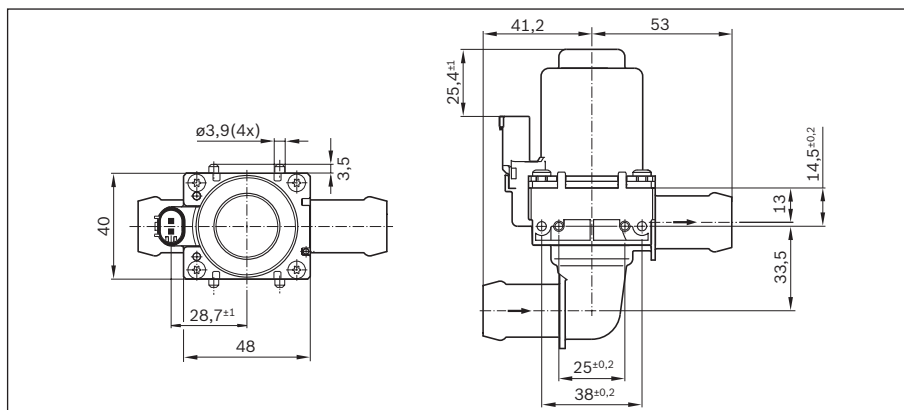
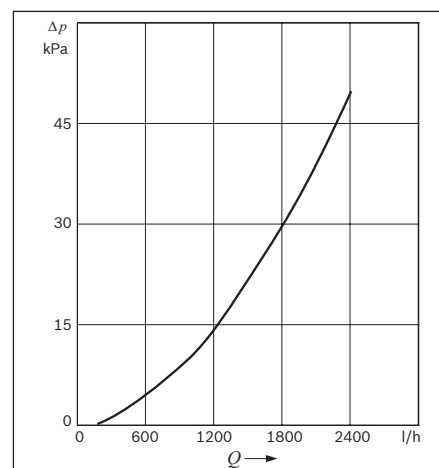
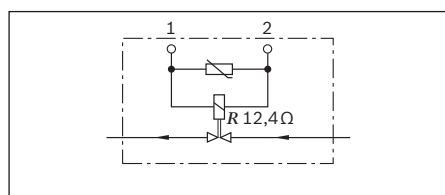



## Switching or timing valves

Similar to original picture

### 24 V

Part number	<b>1 147 412 204</b>
Nominal voltage	$U_N$ 24 V
Resistance	$R_{20}$ 48 $\Omega$
Pressure drop	$\Delta p$ 45 kPa
at a throughput of	$\dot{V}$ 2000 dm <sup>3</sup> ·h <sup>-1</sup>
Switchable pressure difference	$\Delta p$ 60 kPa
Switching times	≤ 100 ms
Duty cycle	0 ... 100 %
Degree of protection	IP 5K4
Weight	approx. 0,5 g

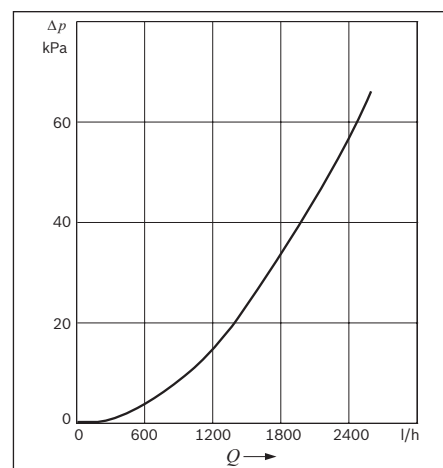
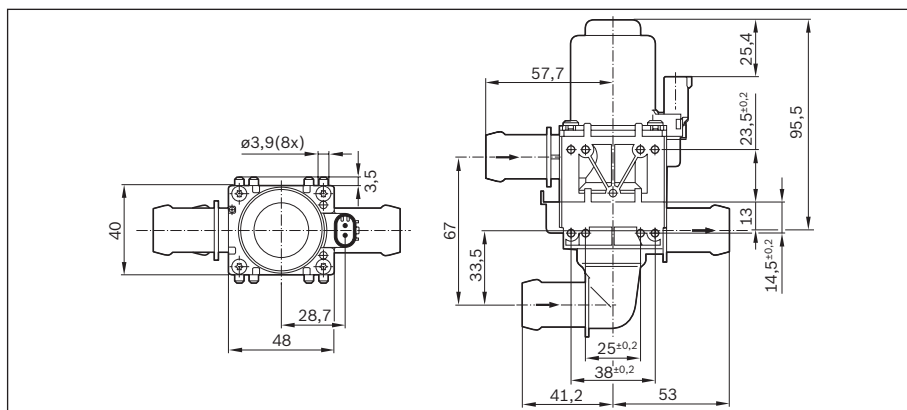
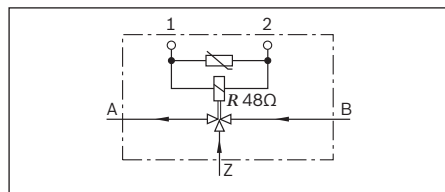

## Switching or timing valves

Similar to original picture

### 12 V

Part number	<b>1 147 412 207</b>
Nominal voltage	$U_N$ 12 V
Resistance	$R_{20}$ 12,4 $\Omega$
Pressure drop	$\Delta p$ 45 kPa
at a throughput of	$\dot{V}$ 2000 dm <sup>3</sup> ·h <sup>-1</sup>
Switchable pressure difference	$\Delta p$ 60 kPa
Switching times	≤ 100 ms
Duty cycle	0 ... 100 %
Degree of protection	IP 5 K 4
Weight	approx. 450,0 g

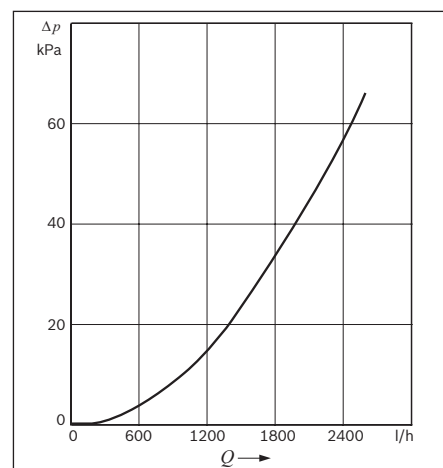
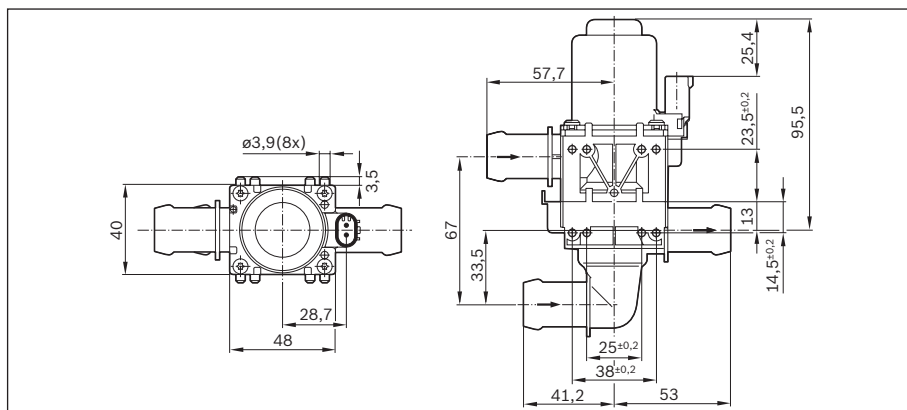
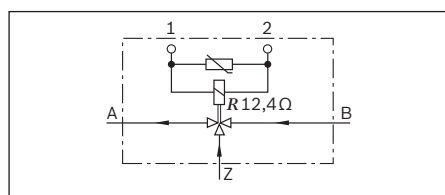

## PAD Water-circulation pumps with brushless drive



### Advantages for your application

The essential advantages of the PAD auxiliary water pump in comparison to pumps, which are driven by carbon-brush mechanically-commutated electric motors, are:

- ▶ A reduction in installation length of up to approx. one third
- ▶ Approx. half the weight
- ▶ High delivery rate
- ▶ Longer service life
- ▶ Better efficiency
- ▶ Quieter operation

The PAD is a rotary pump. The stator and electronics are mechanically fully-separated from the rotor in the dry motor housing. The electronics and the stator winding generate an alternating electrical magnetic field, which in turn drives the rotor. The rotor, as part of the pump wheel, is seated in the separate pump housing. The non-contact torque transmission serves to ensure that throughout the entire service life coolant does not come into contact with the electronics.

### Application examples

For versatile applications Bosch offers auxiliary water pumps with electronically commutated drive motors:

- ▶ Heater circuit
- ▶ Auxiliary heater
- ▶ Charge-air cooling
- ▶ Generator cooling
- ▶ Turbocharger cooling
- ▶ Fuel cooling
- ▶ After-run cooling of combustion engines
- ▶ Thermal management of electric vehicles
- ▶ Battery and electronic cooling

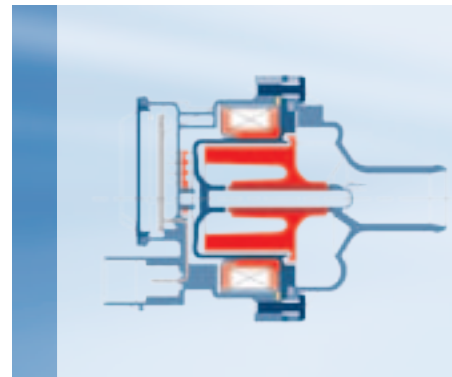

# PAD

## Water-circulating pump driven by brushless motor

### 12 V

Part number	<b>0 392 023 004</b>
Nominal voltage	$U_N$ 12 V
Delivery	$\dot{V}$ 900 dm <sup>3</sup> ·h <sup>-1</sup>
Delivery pressure	$p$ 0,1 bar
Direction of rotation	R
Type of duty	S 1
Degree of protection	IP 69 K
Weight	approx. 0,3 kg

Circuit diagram for connection please contact us

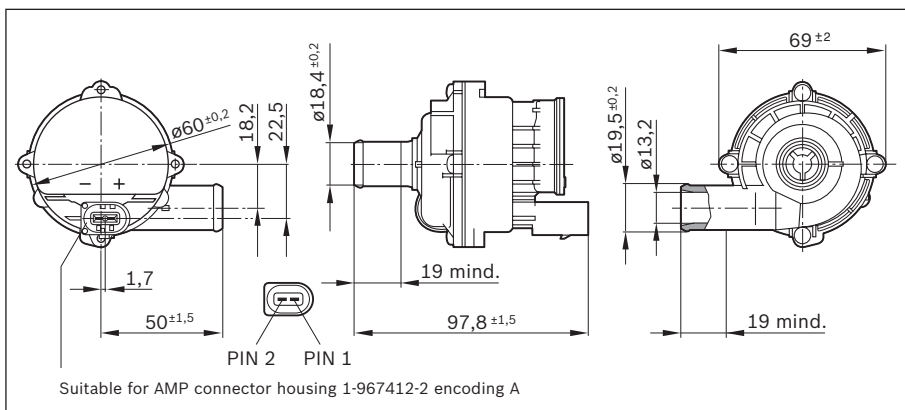
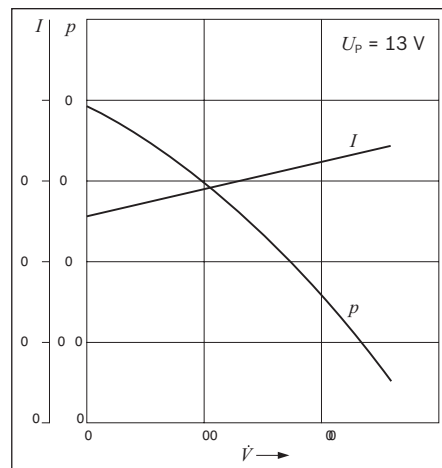



## List of part numbers

Part number	Page	Part number	Page	Part number	Page
0 130 002 525	47	0 390 201 927	15	0 986 337 410	37
0 130 002 527	47	0 390 201 941	16	0 986 338 100	54
0 130 002 529	48	0 390 201 944	16	1 147 412 204	65
0 130 002 529	48	0 390 201 948	11	1 147 412 205	63
0 130 002 613	49	0 390 201 949	11	1 147 412 207	65
0 130 002 632	50	0 390 201 964	12	1 147 412 208	63
0 130 002 633	50	0 390 201 972	17	1 147 412 218	64
0 130 002 634	51	0 390 201 973	17	3 137 230 005	56
0 130 002 636	51	0 390 201 989	18	3 137 230 006	56
0 130 002 671	52	0 390 201 997	18	F 006 B20 092	28
0 130 002 674	52	0 390 201 999	19	F 006 B20 093	29
0 130 101 516	55	0 390 203 224	19	F 006 B20 095	29
0 130 101 616	55	0 390 203 225	19	F 006 B20 096	30
0 130 115 152	57	0 390 203 226	20	F 006 B20 097	30
0 130 115 154	57	0 390 203 227	20	F 006 B20 098	31
0 130 115 604	61	0 390 203 229	20	F 006 B20 099	31
0 130 822 488	26	0 390 203 306	21	F 006 B20 100	32
0 130 822 489	26	0 390 203 307	21	F 006 B20 101	32
0 130 822 490	26	0 390 203 308	21	F 006 B20 102	33
0 130 822 491	26	0 390 203 309	21	F 006 B20 103	33
0 130 822 492	27	0 390 203 310	22	F 006 B20 106	34
0 130 822 493	27	0 390 203 311	22	F 006 B20 411	35
0 130 822 494	27	0 390 203 312	22	F 006 B20 412	35
0 130 822 495	27	0 390 203 313	22	F 006 B20 413	35
0 132 801 141	43	0 390 203 314	23		
0 132 801 142	43	0 390 203 315	23		
0 132 801 143	44	0 390 203 316	23		
0 132 801 346	44	0 390 203 317	23		
0 132 801 347	45	0 390 203 386	24		
0 390 201 900	12	0 390 203 431	24		
0 390 201 901	13	0 390 204 027	25		
0 390 201 902	13	0 390 204 092	53		
0 390 201 903	14	0 390 248 015	41		
0 390 201 904	14	0 390 248 016	41		
0 390 201 912	12	0 390 257 693	28		
0 390 201 913	13	0 392 023 004	67		
0 390 201 914	13	0 986 337 400	36		
0 390 201 914	14	0 986 337 401	36		
0 390 201 915	14	0 986 337 402	37		
0 390 201 925	15	0 986 337 409	37		







If you have any special requirements that are not covered by our range of sensors, please specify this in the data sheet below. In the event of any modifications, please state the known product here.

**Please use this printed data sheet as a master copy and return the filled out copy.**

Bosch part number:

Address:	Sender (customer): <input type="checkbox"/> Mr <input type="checkbox"/> Ms Name: _____ Company: _____ Department: _____ Address: _____ Town/Zip: _____ Tel.: _____ Fax: _____ E-mail: _____
----------	--

Your reference/dated:	Our dept./person in charge:	Telephone (extension):	Date:
-----------------------	-----------------------------	------------------------	-------

**Project description:**

Application / intended use:

New project:	Specification available: <input type="checkbox"/> Yes <input type="checkbox"/> No
Replacement for existing solution:	Drawing available: <input type="checkbox"/> Yes <input type="checkbox"/> No
Competitors used:	External sample available: <input type="checkbox"/> Yes <input type="checkbox"/> No

Required quantity: <input type="checkbox"/> One-off _____ units Required delivery date: Specified quantity on following dates:	Type part no.: Forecast service life produced: Customer price expectation: Notes:												
<table border="1" style="width:100%; border-collapse: collapse;"> <tr> <td style="width:10%;">Date:</td> <td style="width:10%;"></td> <td style="width:10%;"></td> <td style="width:10%;"></td> <td style="width:10%;"></td> <td style="width:10%;"></td> </tr> <tr> <td>Quantity:</td> <td></td> <td></td> <td></td> <td></td> <td></td> </tr> </table>	Date:						Quantity:						
Date:													
Quantity:													
<input type="checkbox"/> Annual _____ units <input type="checkbox"/> Monthly _____ units													

**Sensor requirements:**

Measurement value:  
  
 Additional conditions:  
  
 Conditions of use:

Remarks: